

# SDC Security Door Controls

801 Avenida Acaso, Camarillo, Ca. 93012 • (805) 494-0622 •  
 www.sdcsecurity.com • E-mail: service@sdsecurity.com

## INSTALLATION INSTRUCTIONS - MODEL UR-1 UNIVERSAL RELAY MODULE

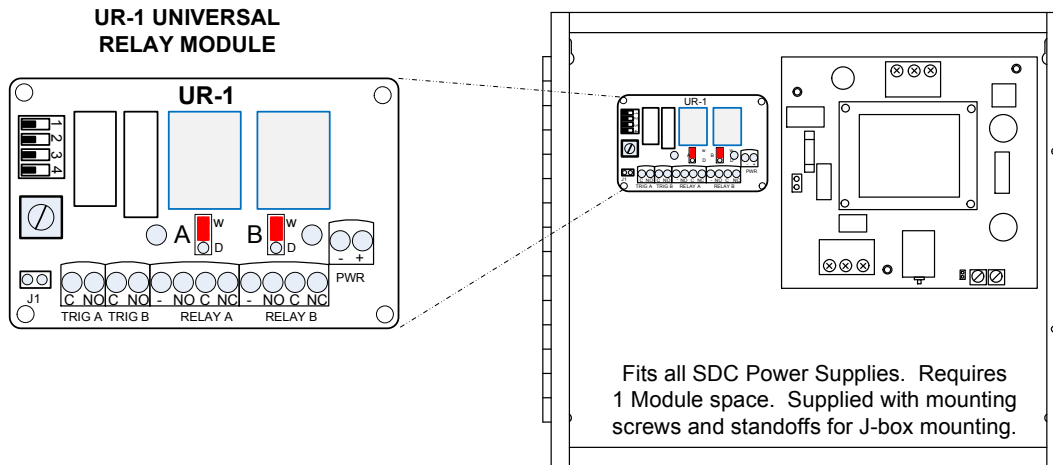

### FEATURES AND BENEFITS

- Microprocessor based relay controller that provides multiple, field selectable operational modes for up to two door stations.
- Each output relay is field selectable as a dry contact or voltage output.
- Centralized wiring for all locks, access controls, monitoring contacts and peripheral equipment.
- 1 or 2 controllers may be installed in SDC 600 series power supplies
- Field selectable relay modes include:
  - Conventional Relay (CR)
  - Dual Conventional Relay (2X CR)
  - Time Delay Relay (TD) – 1 to 60 Seconds
  - Dual Time Delay Relay (2X TD)
  - Latching Relay (LR) – Separate Latch and Release Inputs
  - Dual Latching Relay – (2X LR) Pulse On, Pulse Off Inputs
  - Time Delay/Latching Relay
  - Interlock A (airlock)
  - Interlock B (2 modules required)

### UR-1 TECHNICAL SPECIFICATIONS

INPUT VOLTAGE	12 or 24VDC +/- 10%
INPUT CONTROLLER CURRENT	120/175mA
INPUTS	2 ea Dry Signal Inputs
OUTPUTS	2 ea 10 amp @ 30VDC (resistive) SPDT Lock Outputs (Configurable Wet or Dry). Wet output voltage is the same as the module power IN voltage.
DIMENSIONS	3.20"W x 2.00" L x 1.0" H [81.28mm W x 50.8mm L x 25.4mm H]

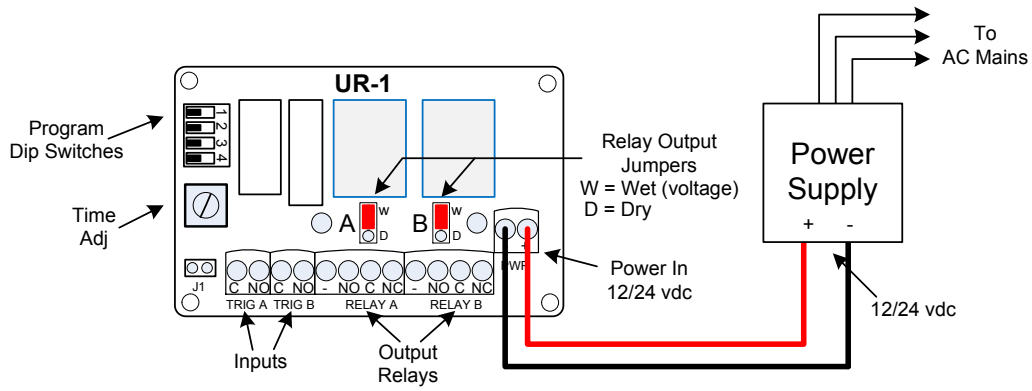

**WARNING!** The UR board Output Relays must be protected against inductive kickback generated when power is removed from an inductive load (e.g., electric strikes). Refer to the lock manufacturer's installation manual or contact the manufacturer for kickback protection recommendations.

### CR Mode

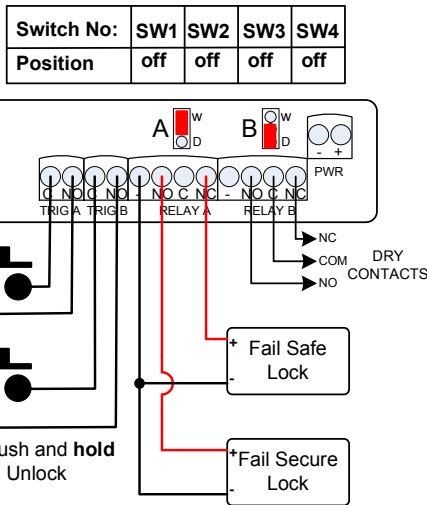

### Dual CR Mode

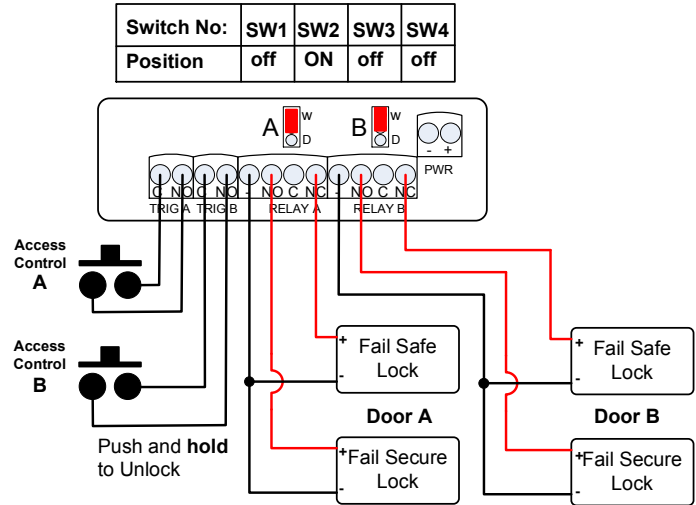

### TD Mode

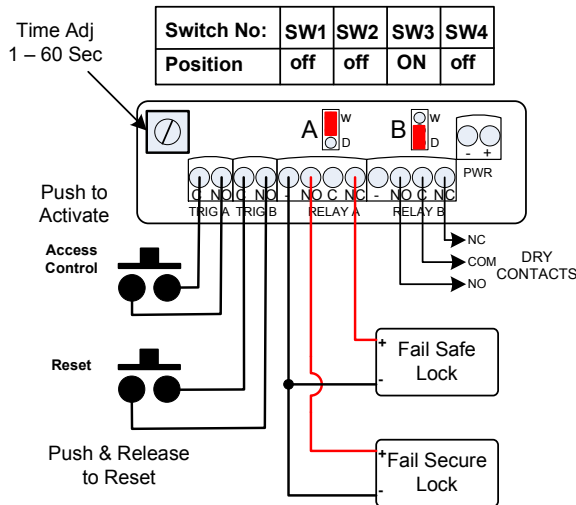

### Dual TD Mode

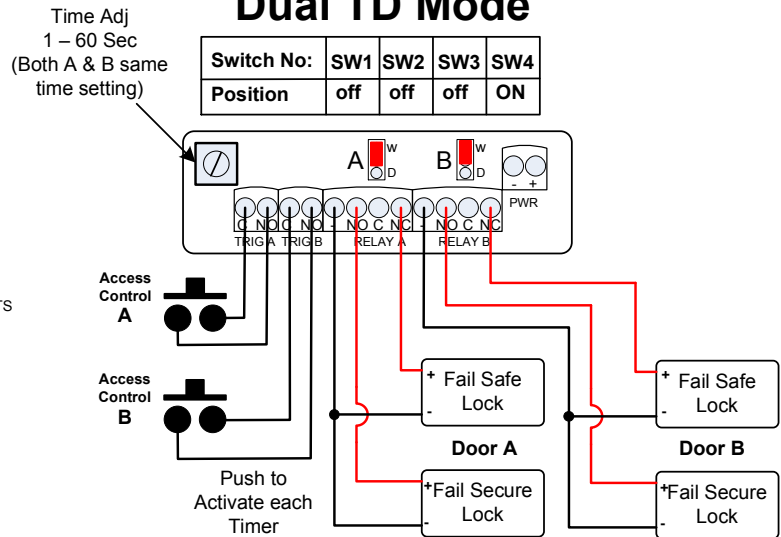

**WARNING!** The UR board Output Relays must be protected against inductive kickback generated when power is removed from an inductive load (e.g., electric strikes). Refer to the lock manufacturer's installation manual or contact the manufacturer for kickback protection recommendations.

## LR Mode

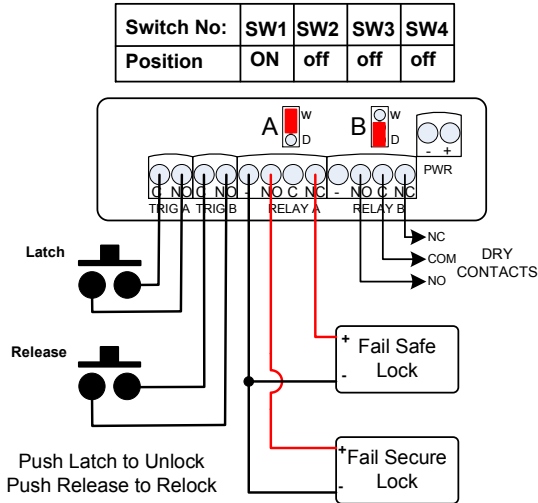

## Dual LR Mode (2 Independent Relays)

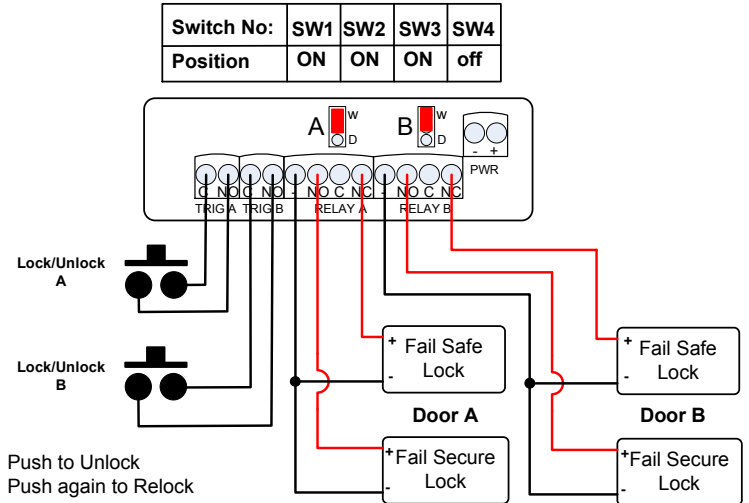

## Sequencer Mode (2 Locking Devices)

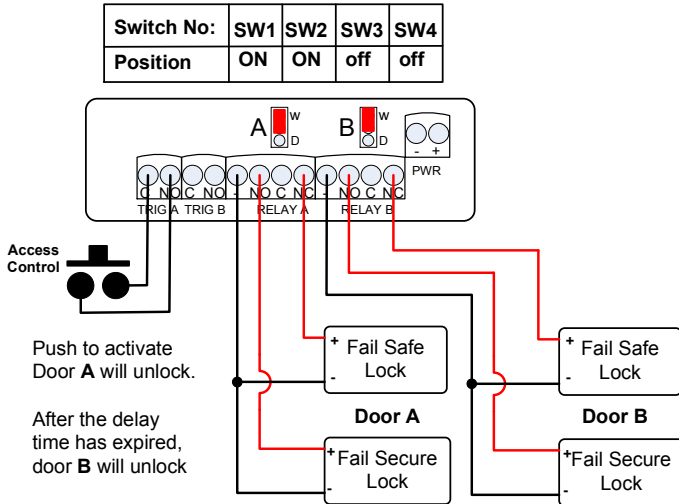

## Sequencer Mode (ELR Device and Door Operator)

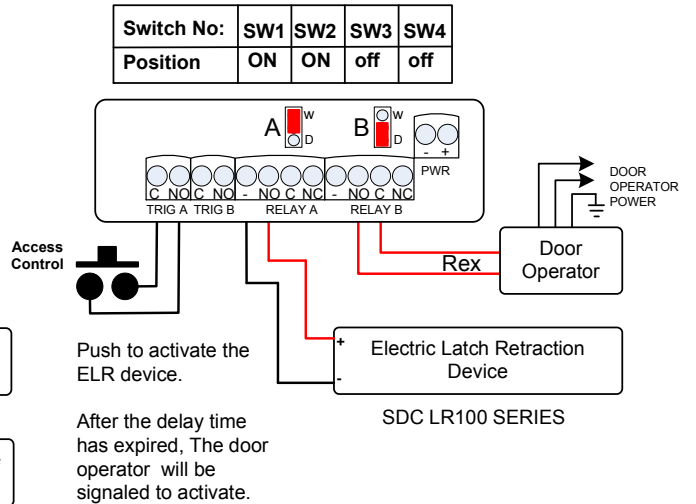

**WARNING!** The UR board Output Relays must be protected against inductive kickback generated when power is removed from an inductive load (e.g., electric strikes). Refer to the lock manufacturer's installation manual or contact the manufacturer for kickback protection recommendations.

## TD/LR Mode

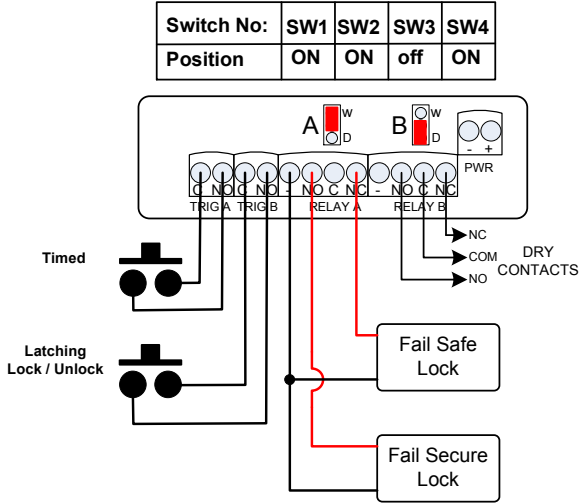

## Interlock A

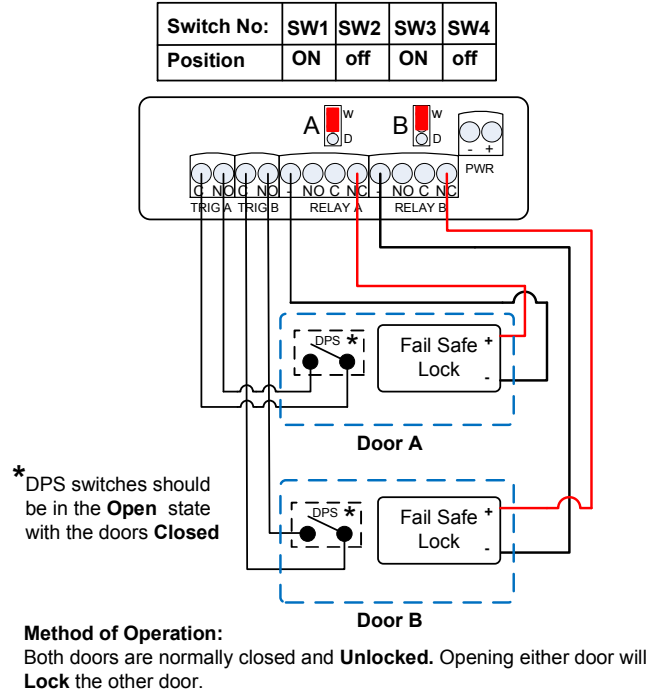

## Interlock B (2 Modules are Required)

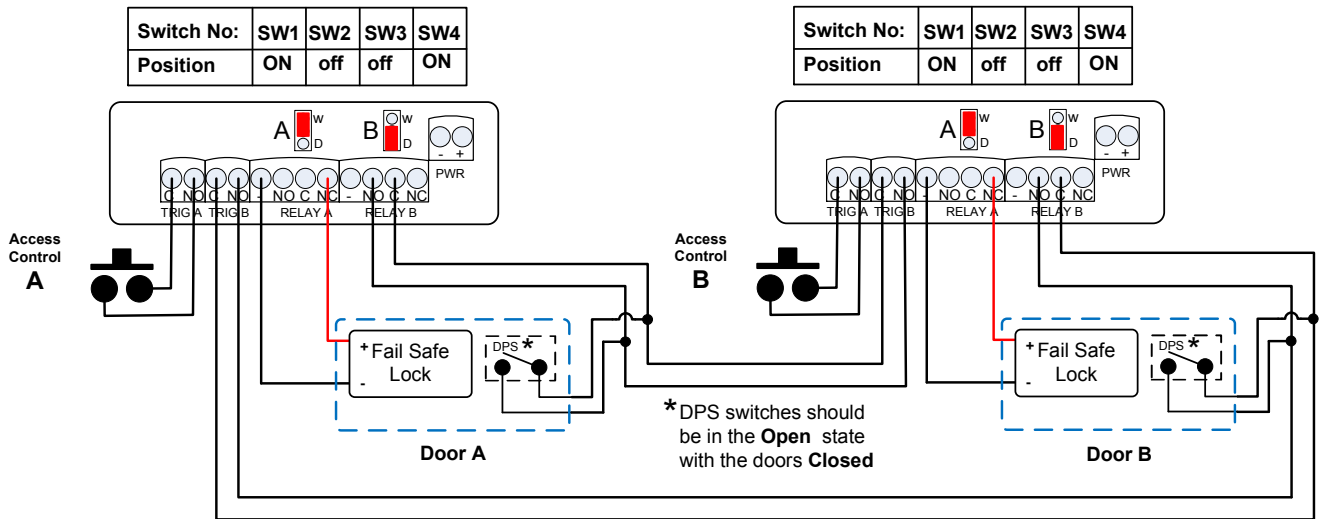

# Communicating Bath Using Fail Safe Electrified Locksets

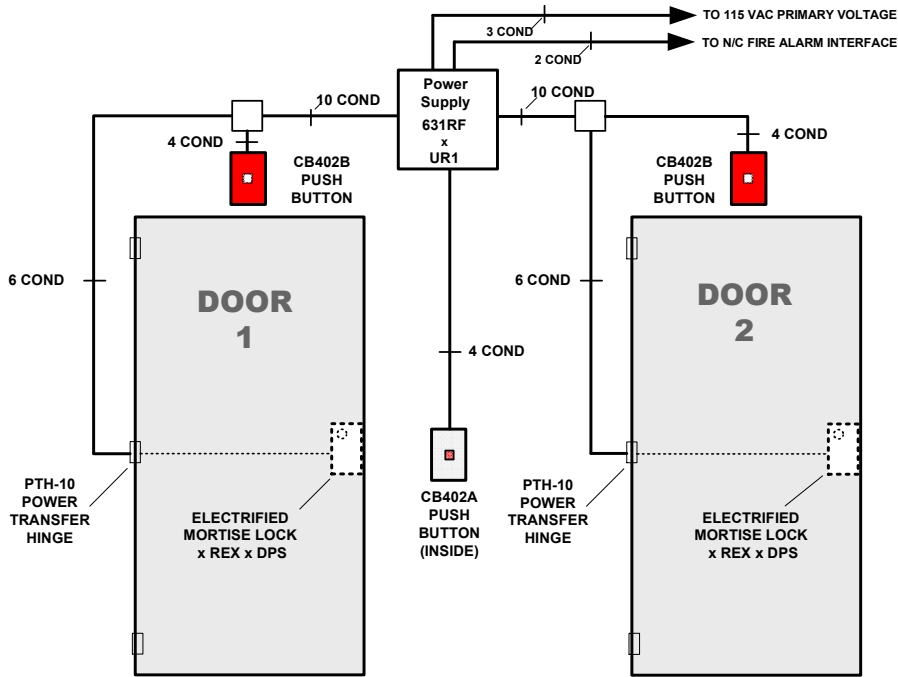

## Method of Operation

Both doors shall be normally unlocked.

### System Activation:

Both doors must be closed to lock. Pressing the CB402A Push Button will lock all the doors.

### Egress:

When the doors are locked, turning either door's inside lever activates the lock's REX switch and unlocks both doors.

### Emergency Release:

When the doors are locked, activating either CB402B Emergency Push Buttons will unlock both the doors.

When used with an SDC 631RF power supply, Both doors will unlock automatically via signal from the fire panel.

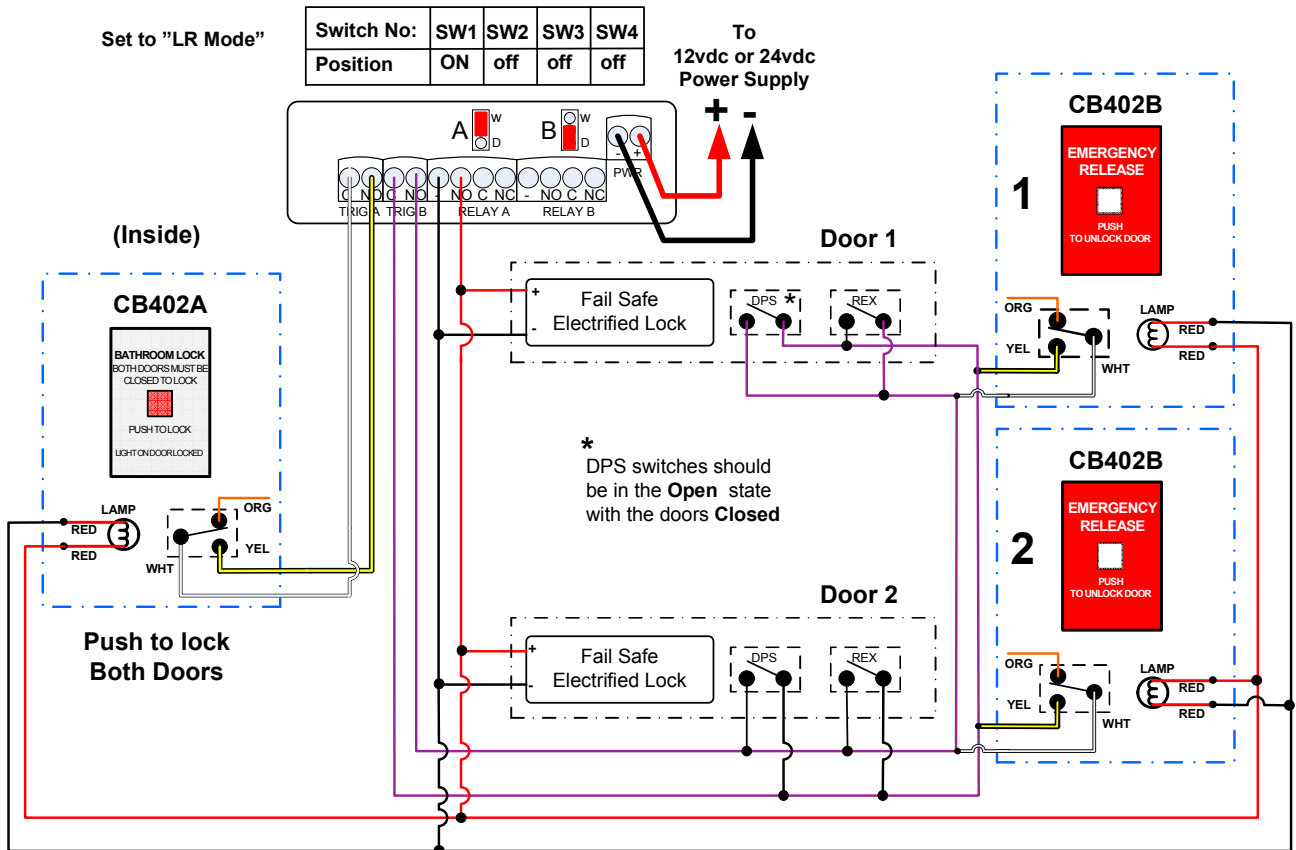

# Communicating Bath Using Magnetic Locks

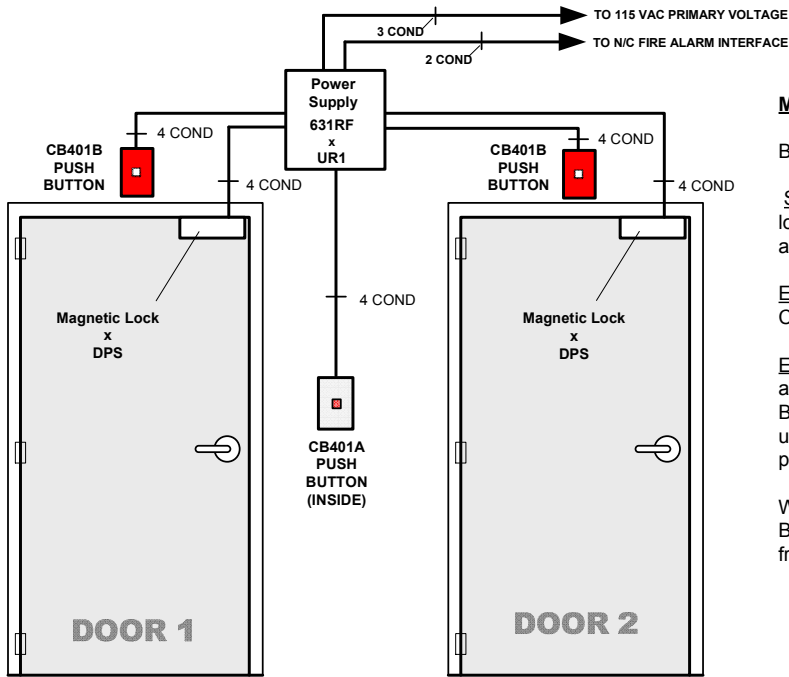

## Method of Operation

Both doors shall be normally unlocked.

**System Activation:** All doors must be closed to lock. Pressing the CB401A Push Button will lock all the doors.

**Egress:** When the doors are locked, pressing the CB401A Push Button again unlocks all the doors.

**Emergency Release:** When the doors are locked, activating either of the CB401B Emergency Push Buttons will unlock both doors. Both doors will unlock automatically via signal from the fire panel.

When used with an SDC 631RF power supply, Both doors will unlock automatically via signal from the fire panel.

