



SAM2-24

600 lbs Shear Aligning Magnalock®

Hidden Strength at Any Angle Ideal for Traffic Control

The compact and versatile SAM2-24 Shear Aligning Magnalock provides 600 lbs of holding force to swinging or sliding doors. It is ideal for traffic control and to secure smaller applications, like sliding closet doors, atriums, and more. The SAM2-24 mounts fully concealed into wood, steel, aluminum or Herculite doors in any position: at the header, door edge or threshold.

PRODUCT FEATURES

- Direct mount to door frame for strength and reliability
- Compact design fits tight spaces
- Fully sealed for weatherproof operations
- 6 ft. [1.8m] of jacketed, stranded conductor cable
- Noise suppression with included MOV
- Instant release circuit - no residual magnetism
- Efficient, low-voltage, low power usage
- Rust resistant - all ferrous metal surfaces plated for durability
- MagnaCare® lifetime replacement, no fault warranty

SPECIFICATIONS

- UL 10C Listed
- CAN4-S104, CAN/ULC-S533 Listed
- ANSI/UL 294 Listed
- ANSI/BHMA A156.23, Grade 1; E08571-1000, E08581-500
- CSFM - California State Fire Marshal Approved
- US Patents: 6,007,119; 6,135,515
- Foreign Patents: AU:741,880; China: ZL98809925.X; EU: 1,021,633

Holding Force:
600 lbs [272kg]

Dimensions:
7-3/16" L x 1-1/8" D x 1" H

Electrical:
62 mA at 24 VDC only

Operating Temperature:
-40 to +140F [-40 to +60C]
Indoor or outdoor use
Not for use in open channel doors

Shipping Weight:
2.5 lbs [1.13kg]

Finishes:
US32D/630 - Satin Stainless Steel



» MODELS

PART # | Description

SAM2-24 | Shear Magnalock - 24 VDC, Mini Version

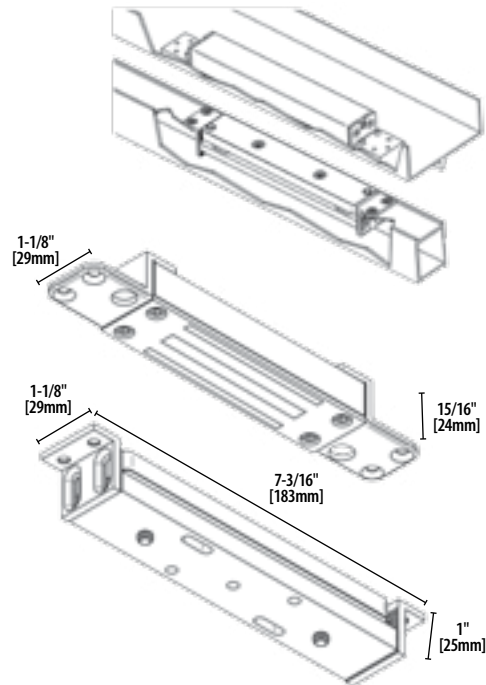

GRADE 1



FIRE RATED

SECURITRON
ASSA ABLOY



MAGNACARE WARRANTY



LISTED