

# SONANCE

## MARINER DATA SHEET

### MARINER 66

#### TECHNICAL SPECIFICATIONS

<b>SKU</b>	<b>Mariner 66</b> 93154 - White   93155 - Black
<b>UOM</b>	Pair
<b>Tweeter</b>	1" (25mm) powder-coated aluminum dome, Ferrofluid cooled, acoustic back chamber
<b>Woofers</b>	6.5" (165mm) Kevlar/Nomex laminated cone, Santoprene™ surround
<b>Frequency Response</b>	50Hz-20Hz +/-3dB
<b>Impedance</b>	8 Ohms nominal; 6 Ohms minimum
<b>Power Handling</b>	5 Watts minimum; 100 Watts maximum
<b>Sensitivity</b>	90dB SPL (2.83V/1 meter)
<b>Environmental</b>	Mill Spec 810 for humidity, salt spray, temperature, UV; IP66 waterproof rating
<b>Environmental Temp</b>	-13° - 149°F(-25°C - 65°C)
<b>Grille Material</b>	Perforated aluminum
<b>Dimensions (WxHxD)</b>	7.51" x 12.14" x 6.86" (191mm x 308mm x 174mm)
<b>Shipping Weight</b>	17 lbs (7.7 kg) pair

#### DIMENSIONAL DRAWINGS

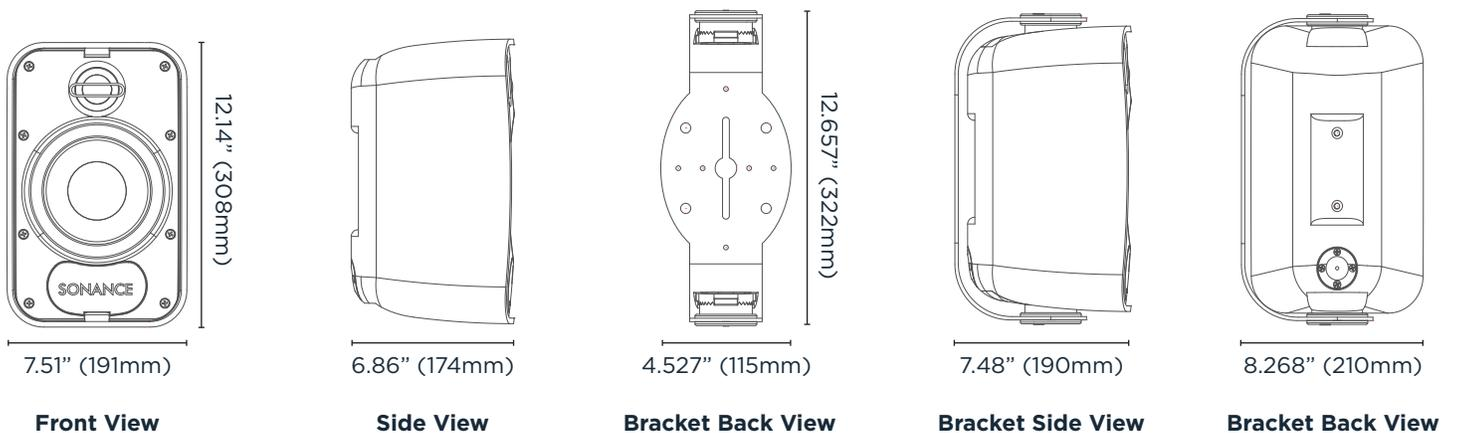

**LIMITED FIVE (5) YEAR WARRANTY** Sonance warrants to the first end-user purchaser that this Sonance-brand product ("Product"), when purchased from an authorized Sonance Dealer/Distributor, will be free from defective workmanship and materials for the period stated above. Sonance will at its option and expense during the warranty period, either repair the defect or replace the Product with a new or remanufactured Product or a reasonable equivalent. For more details please refer to the product manual.

©2021 Sonance. All rights reserved. Sonance is a registered trademarks of Dana Innovations. Due to continuous product improvement, all features and specifications are subject to change without notice. For the latest Sonance product specification information visit our website at [www.sonance.com](http://www.sonance.com).

SONANCE • 991 Calle Amanecer • San Clemente, CA 92673 USA • Phone: (949) 492-7777 • Fax: (949) 361-5151 • Technical Support: (949) 492-7777 • [www.sonance.com](http://www.sonance.com) 08.08.2021