

## Vandal Resistant Hot-Line Panel Phone with Keypad

The **K-1900-8 Series** panel phone can either auto-dial a phone number each time the handset is lifted, be used as a multi-number auto-dialer, or be used as a standard (dumb) phone. The unit will touch tone or pulse dial and will not auto-dial on incoming calls.

The **K-1900-8 Series** housing consists of a heavy gauge stainless steel panel, metal touch tone keypad, armored cable, heavy duty handset, and all metal cradle. The **K-1900-8 Series** can be easily touch tone programmed at the shop or installation site. All programming is stored in non-volatile memory.

The **K-1900-812L** and **K-1900-812L-EWP** feature a 12" long armored cable with an internal stainless steel lanyard for additional cable strength.

The **K-1900-8-EWP** and **K-1900-812L-EWP** share all the features of the **K-1900-8** and **K-1900-812L** in addition to Enhanced Weather Protection (EWP) for outdoor installations where the unit is exposed to precipitation or condensation. EWP products are designed to meet IP66 standards and may feature foam rubber gaskets, sealed connections, gel-filled butt connectors, as well as potted circuit boards with internally sealed, field-adjustable trim pots and DIP switches for easy on-site programming. For more information on EWP, see **DOD 859**.

**Note:** If a ringer is required, use an external unit such as the Viking **SR-1 (DOD 477)**, or **LPR-1 (DOD 550)**.

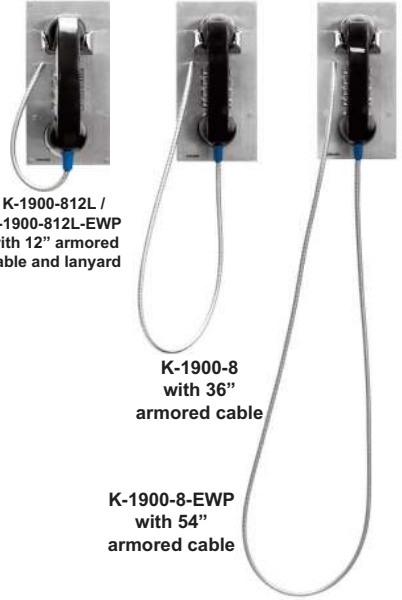

**K-1900-812L /  
K-1900-812L-EWP**  
with 12" armored  
cable and lanyard

**K-1900-8**  
with 36"  
armored cable

**K-1900-8-EWP**  
with 54"  
armored cable

### Features

- **Vandal Resistant Features:** 12 gauge (0.105" thick) 316 stainless steel panel with permanent laser etched graphics, armored cable, metal cradle, heavy-duty metal keypad, and hex drive mounting screws
- **Weather Resistant Features:** Marine grade 316 stainless steel faceplate and screws, and internally sealed keypad
- Auto dials one programmable speed dial number (up to 32 digits)
- Multi-number dialer mode adds 5 speed dial numbers (up to 16 digits)
- Touch tone or pulse dialing
- Non-volatile memory (no batteries required)
- Operates on analog PABX and key system extensions or analog Centrex and CO lines
- Programmable 6 digit security code
- Touch tone programmable
- Optional Enhanced Weather Protection (EWP) available - EWP products are designed to meet IP66 Ingress Protection Rating, see **DOD 859**
- 12" armored handset cable on **K-1900-812L** and **K-1900-812L-EWP**
- 36" armored handset cable on **K-1900-8**
- 54" armored handset cable on **K-1900-8-EWP**
- Programmable pre-dial pause
- Blocks fraudulent calls from hand held pocket dialers
- Limited toll Restriction in dumb phone mode
- Hearing aid compatible amplified handset with sealed push button volume control
- Programmable default volume level
- Programmable volume control disable
- Flush mount with included steel rough-in box, or use an optional **VE-5x10** surface mount box (not included, see **DOD 424**)

### Applications

- Catalog sales
- Kiosks
- Courtesy and customer service phones
- Automated tellers (ATM's)
- Hot-line reservation phones
- Security and emergency phones
- Replaces leased ringdown circuits
- Gate/entrance communication in noisy locations (diesel trucks, factory noise, etc.)

### Specifications

- **Power:** Telephone line powered (20V DC/18mA minimum)
- **Dimensions for Standard Model**  
  - **Phone :** 5.0" x 10.0" x 4.54" (127mm x 254mm x 113mm)
  - **With rough-in box:** 5.0" x 10.0" x 5.53" (127mm x 254mm x 141mm)
- **Dimensions for EWP Model**  
  - **Phone:** 5.0" x 10.0" x 4.93" (127mm x 254mm x 125mm)
  - **With rough-in box:** 5.0" x 10.0" x 5.61" (127mm x 254mm x 143mm)
- **Shipping Weight:** 5 lbs (2.3 kg)
- **Operating Temperature:** -30°F to 140°F (-34°C to 60°C)
- **Humidity - Standard Model:** 5% to 95% non-condensing
- **Humidity - EWP Model :** Up to 100% condensing
- **K-1900-812L(EWP) Handset Cable Length:** 12" to 12.7" (31 cm to 33 cm)
- **K-1900-8 Handset Cable Length:** 34" to 37" (86 cm to 94 cm)
- **K-1900-8-EWP Handset Cable Length:** 52" to 57" (132 cm to 145 cm)
- **Touch Tone Dial Speed:** Normal = 120ms on/off, Fast = 50ms on/off
- **Pulse Dial Speed:** Normal = 10 pps, Fast = 20 pps
- **Connections:** (2) gel-filled butt connectors

## Installation

To install the **K-1900-8** panel phone, attach the panel using the provided screws or use the optional **VE-5x10** weather resistant surface mount box. **Note:** Four extra screws and nuts are provided to fill the unused mounting holes. The optional **VE-5x10** surface mount box (shown below) is designed to be surface mounted to a wall, post, single gang box or a **VE-GNP** or **VE-GNP-2** goose neck pedestal (shown right). The **K-1900-8** can also be mounted in an optional **VE-9x20** Weatherproof Enclosure (**DOD 413**). **Note:** When mounting a **K-1900-8-EWP** in a **VE-9x20**, the length of the handset cable must be reduced. Use a 3/32" hex key or bit to loosen the set screw in the brass handset cable retainer. Pull approximately 18 inches of the cable through the panel and retighten the set screw.

**IMPORTANT:** Electronic devices are susceptible to lightning and power station electrical surges from both the AC outlet and the telephone line. It is recommended that a surge protector be installed to protect against such surges.

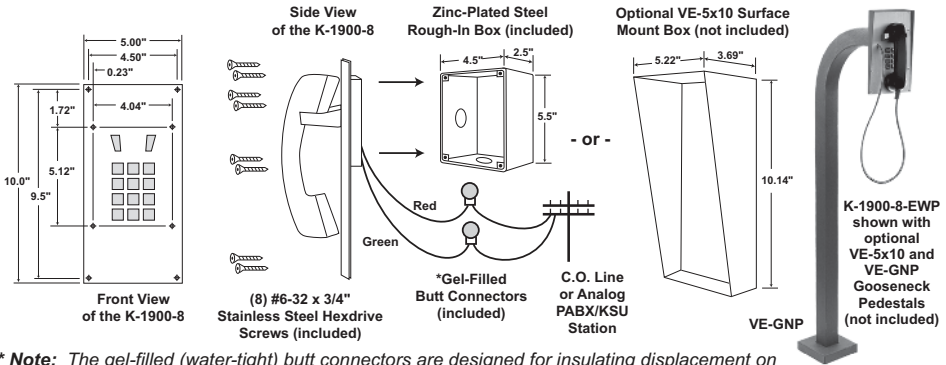

**\* Note:** The gel-filled (water-tight) butt connectors are designed for insulating displacement on 19-26 gauge wire with a maximum insulation of 0.082 inches. Cut off stripped wire ends before terminating.

## Programming

### A. Security Code

A six digit number may be used to access the programming mode. The security code has been factory set to **845464** (V-I-K-I-N-G). It is recommended that you change the security code to a personal 6 digit number:

<b>Step 1.</b>	Access programming as shown in section B.
<b>Step 2.</b>	Enter your new security code followed by <b>#47</b> .
<b>Step 3.</b>	To exit programming simply hang up the <b>K-1900-8</b> .

**Note:** The security code must be six digits in length and **MUST NOT** contain a \* or #. If you have forgotten your security code, see section "B, 2. Programming Without Using the Security Code."

### B. Accessing the Programming Mode

#### 1. Remote Programming

<b>Step 1.</b>	Connect the green and red wires on the <b>K-1900-8</b> to a C.O. line or analog PABX/KSU station.
<b>Step 2.</b>	If using the multi-number dialer mode, set DIP switch 2 to <b>ON</b> .
<b>Step 3.</b>	From a Touch Tone phone, call the line connected to the <b>K-1900-8</b> .
<b>Step 4.</b>	Take the <b>K-1900-8</b> off-hook (remove handset from the cradle). From the calling phone enter "*" followed by the six digit security code, factory set to <b>845464</b> (see section A above). A double beep will indicate that programming has been entered.
<b>Step 5.</b>	Program as shown in sections D - I.
<b>Step 6.</b>	To exit programming, hang up both phones.

#### 2. Programming Without Using the Security Code

<b>Step 1.</b>	Connect the green and red wires on the <b>K-1900-8</b> to a C.O. line or analog PABX/KSU station.
<b>Step 2.</b>	Set DIP switch 1 to <b>ON</b> .
<b>Step 3.</b>	If using the multi-number dialer mode, set DIP switch 2 to <b>ON</b> .
<b>Step 4.</b>	From a Touch Tone phone, call the line connected to the <b>K-1900-8</b> .
<b>Step 5.</b>	Take the <b>K-1900-8</b> off-hook (remove handset from cradle). A double beep should be heard indicating you have entered programming.
<b>Step 6.</b>	Program from calling phone as shown in sections D - I.
<b>Step 7.</b>	Set DIP switch 1 back to <b>OFF</b> .
<b>Step 8.</b>	To exit programming, simply hang-up the phones.

## C. Programming Features Quick Reference

Description	Enter Digits	+ Location
Speed dial number .....	1-32 digit (0-9)	+ #00
Multi-number auto-dialer numbers 1-5 (DIP switch 2 must be ON) .....	1-32 digit (0-9)	+ #01-#05
* (anywhere in the speed dial number) .....	**	
# (anywhere in the speed dial number) .....	*#	
Set dialing speed to normal (Touch Tones: 120ms on/off, Pulse: 10 pps) (factory setting) .....	*1	
Set dialing speed to fast (Touch Tones: 50ms on/off, Pulse: 20 pps) .....	*2	
Block hand held pocket dialers (factory setting) .....	*3	
Allow hand held pocket dialers .....	*4	
Normal pre-dial pause (approximately 1.4 sec) (factory setting) .....	*5	
Short pre-dial pause (approximately 800 ms) .....	*6	
To add a one second pause at any point in the dialing string .....	#7	
To add a four second pause at any point in the dialing string .....	*7	
Toggle between Pulse and Touch Tone dialing (see section I) .....	*8	
Disable toll restriction (factory setting) .....	*9	
Enable toll restriction .....	*0	
Set default volume 1-4 (1 = min, 4 = max) and control (1 = enabled, 2 = disabled) (factory 1,1) .....	2 digits (1-4,1-2)	+ #46
Change security code .....	6 digits (0-9)	+ #47
To clear the speed dial number and return all programming to factory settings .....	###	

**Note:** Special features such as \*, #, a mode change and a pause, use single digits in the programming memory.

## D. Dialer Modes

The **K-1900-8** can operate in 3 different modes. With DIP switch 2 set to **OFF** and memory location #00 cleared, the **K-1900-8** is in the Standard (Dumb) Phone mode. With DIP switch 2 set to **OFF** and a phone number programmed in memory location #00, the **K-1900-8** is in the Single Number Auto-Dialer mode. With DIP switch 2 set to **ON**, the **K-1900-8** becomes a Multi-Number Auto Dialer.

## E. Dialing Speed

To set the dialing speed, access the **Programming** mode as shown in section B, then choose a speed. To set the dialing speed to **Normal** (Touch Tone: 120ms on/off, Pulse: 10pps), enter \*1. To set the dialing speed to **Fast** (Touch Tone: 60ms on/off, Pulse: 20pps), enter \*2.

## F. Hand Held Pocket Dialers

The **K-1900-8** is programmed to hang-up if it detects Touch Tones it did not generate. This helps prevent toll fraud from hand held dialers. To set the **K-1900-8** to block/allow dialing from external devices, access the **Programming** mode as shown in section B, then choose block or allow. To **Block** hand held dialers, enter \*3. To **Allow** Touch Tones from external devices, enter \*4.

## G. Pre-Dial Pause

In the single number auto-dialer mode, the time from when the handset is taken off-hook until the **K-1900-8** auto-dials can be programmed. Access the **Programming** mode (section B), then choose a pause length. To set the pause length to **Normal** (approximately 1.4 seconds), enter \*5. To set the pause length to **Short** (approximately 800ms) enter \*6.

## H. Pauses in the Dialing String

To set pauses in the dialing string, access the **Programming** mode as shown in section B, then enter \*7 to put a 4 second pause anywhere in the dialing string, or #7 for a 1 second pause.

## I. Toll Restriction

When the **K-1900-8** is in the Standard (Dumb) phone mode, some limited toll restriction is available. With toll restriction enabled, the phone will hang-up if a 0 or 1 is entered as the first digit, or if more than ten digits are entered. Access the **Programming** mode (section B), then choose enable or disable toll restriction. To set the **K-1900-8** to **Disable** toll restriction, enter \*9. To set the **K-1900-8** to **Enable** toll restriction, enter \*0.

## J. DIP Switch Programming

Switch	Position	Description
1	ON	Learn Mode
1	OFF	Normal Operation (factory setting)
2	ON	Multi-Number Dialer Mode
2	OFF	Normal Operation (factory setting)

**Note:** DIP switch 3 is not used and should remain in the OFF position.

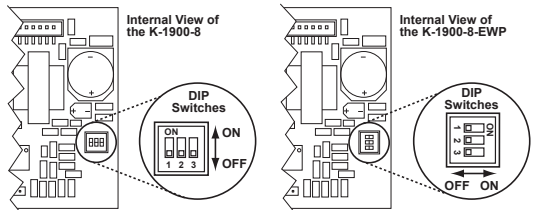

## K. Programming Examples

These examples would be entered after accessing the Programming mode as shown in section B.

To Program the K-1900-8 to...	Enter Digits	Enter Location
...Touch Tone dial 555-1234	5551234	#00
...pulse dial 555-1234 followed by a Touch Tone 9	*8 5551234 *8 9	#00
...clear the speed dial number		#00

# Operation

## A. Single Number Auto Dialer

In the single number auto dialer mode (see **Programming section D**), when the **K-1900-8** is taken off-hook it will speed dial the phone number programmed in memory location **#00**. After speed dialing is complete, the keypad is available for user Touch Tone signaling. In this mode, the **K-1900-8** can be programmed to block hand held dialers (see **Programming section F**).

## B. Standard (Dumb) Phone Mode

If nothing is programmed in memory locations **#00**, the **K-1900-8** drops into the dumb phone mode. The phone will act like any standard 2500 type telephone. The only feature which may be enabled is the limited toll restriction (see **Programming section I**).

## C. Multi-Number Auto Dialer

In the multi-number auto dialer mode (see **Programming section D**), when the **K-1900-8** is taken off-hook it will dial one of six speed dial numbers programmed in memory locations **#01**, **#02**, **#03**, **#04**, **#05** and **#00** when the user presses 1, 2, 3, 4, 5, or 0 (respectively) on the keypad. After speed dialing is complete, the keypad is available for user Touch Tone signaling. In this mode, the **K-1900-8** can be programmed to block hand held pocket dialers (see **Programming section F**).

## B. Handset Receiver Volume Adjustment

The **K-1900-8** has a sealed push button switch located on the inside handle of the handset. Each push of the button will rotate through the receiver volume levels if enabled. After four actuations, the receiver volume is back to its default setting. Hanging up the phone will automatically set the receiver volume to its default setting.

# Warranty

**IF YOU HAVE A PROBLEM WITH A VIKING PRODUCT, CONTACT: VIKING TECHNICAL SUPPORT AT 715-386-8666**

Our Technical Support Department is available for assistance Monday through Friday 8am - 5pm central time. So that we can give you better service, before you call please:

1. Know the model number, the serial number and what software version you have (see serial label).
2. Have your Product Manual in front of you.
3. It is best if you are on site.

### RETURNING PRODUCT FOR REPAIR

The following procedure is for equipment that needs repair:

1. Customer must contact Viking's Technical Support Department at 715-386-8666 to obtain a Return Authorization (RA) number. The customer MUST have a complete description of the problem, with all pertinent information regarding the defect, such as options set, conditions, symptoms, methods to duplicate problem, frequency of failure, etc.
2. Packing: Return equipment in original box or in proper packing so that damage will not occur while in transit. Static sensitive equipment such as a circuit board should be in an anti-static bag, sandwiched between foam and individually boxed. All equipment should be wrapped to avoid packing material lodging in or sticking to the equipment. Include ALL parts of the equipment. C.O.D. or freight collect shipments cannot be accepted. Ship cartons prepaid to: **Viking Electronics, 1531 Industrial Street, Hudson, WI 54016**
3. Return shipping address: Be sure to include your return shipping address inside the box. We cannot ship to a P.O. Box.
4. RA number on carton: In large printing, write the R.A. number on the outside of each carton being returned.

### RETURNING PRODUCT FOR EXCHANGE

The following procedure is for equipment that has failed out-of-box (within 10 days of purchase):

1. Customer must contact Viking's Technical Support at 715-386-8666 to determine possible causes for the problem. The customer MUST be able to step through recommended tests for diagnosis.
2. If the Technical Support Product Specialist determines that the equipment is defective based on the customer's input and troubleshooting, a Return Authorization (R.A.) number will be issued. This number is valid for fourteen (14) calendar days from the date of issue.
3. After obtaining the R.A. number, return the approved equipment to your distributor, referencing the R.A. number. Your distributor will then replace the Viking product using the same R.A. number.
4. The distributor will NOT exchange this product without first obtaining the R.A. number from you. If you haven't followed the steps listed in 1, 2 and 3, be aware that you will have to pay a restocking charge.

## TWO YEAR LIMITED WARRANTY

Viking warrants its products to be free from defects in the workmanship or materials, under normal use and service, for a period of two years from the date of purchase from any authorized Viking distributor. If at any time during the warranty period, the product is deemed defective or malfunctions, return the product to Viking Electronics, Inc., 1531 Industrial Street, Hudson, WI, 54016. Customer must contact Viking's Technical Support Department at 715-386-8666 to obtain a Return Authorization (R.A.) number.

This warranty does not cover any damage to the product due to lightning, over voltage, under voltage, accident, misuse, abuse, negligence or any damage caused by use of the product by the purchaser or others. This warranty does not cover non-EWP products that have been exposed to wet or corrosive environments. This warranty does not cover stainless steel surfaces that have not been properly maintained.

**NO OTHER WARRANTIES. VIKING MAKES NO WARRANTIES RELATING TO ITS PRODUCTS OTHER THAN AS DESCRIBED ABOVE AND DISCLAIMS ANY EXPRESS OR IMPLIED WARRANTIES OR MERCHANTABILITY OR FITNESS FOR ANY PARTICULAR PURPOSE.**

**EXCLUSION OF CONSEQUENTIAL DAMAGES. VIKING SHALL NOT, UNDER ANY CIRCUMSTANCES, BE LIABLE TO PURCHASER, OR ANY OTHER PARTY, FOR CONSEQUENTIAL, INCIDENTAL, SPECIAL OR EXEMPLARY DAMAGES ARISING OUT OF OR RELATED TO THE SALE OR USE OF THE PRODUCT SOLD HEREUNDER.**

**EXCLUSIVE REMEDY AND LIMITATION OF LIABILITY. WHETHER IN AN ACTION BASED ON CONTRACT, TORT (INCLUDING NEGLIGENCE OR STRICT LIABILITY) OR ANY OTHER LEGAL THEORY, ANY LIABILITY OF VIKING SHALL BE LIMITED TO REPAIR OR REPLACEMENT OF THE PRODUCT, OR AT VIKING'S OPTION, REFUND OF THE PURCHASE PRICE AS THE EXCLUSIVE REMEDY AND ANY LIABILITY OF VIKING SHALL BE SO LIMITED.**

**IT IS EXPRESSLY UNDERSTOOD AND AGREED THAT EACH AND EVERY PROVISION OF THIS AGREEMENT WHICH PROVIDES FOR DISCLAIMER OF WARRANTIES, EXCLUSION OF CONSEQUENTIAL DAMAGES, AND EXCLUSIVE REMEDY AND LIMITATION OF LIABILITY, ARE SEVERABLE FROM ANY OTHER PROVISION AND EACH PROVISION IS A SEPARABLE AND INDEPENDENT ELEMENT OF RISK ALLOCATION AND IS INTENDED TO BE ENFORCED AS SUCH.**

### FCC REQUIREMENTS

This equipment complies with Part 68 of the FCC rules and the requirements adopted by the ACTA. On the side of this equipment is a label that contains, among other information, a product identifier in the format USAAEQ##TXXXX. If requested, this number must be provided to the telephone company.

The REN is used to determine the number of devices that may be connected to a telephone line. Excessive REN's on a telephone line may result in the device not ringing in response to an incoming call. In most but not all areas, the sum of the REN's should not exceed five (5.0). To be certain of the number of devices that may be connected to a line, as determined by the total REN's, contact the local telephone company. For products approved after July 23, 2001, the REN for this product is part of the product identifier that has the format USAAEQ##TXXXX. The digits represented by ## are the REN without a decimal point (e.g., .03 is a REN of 0.3). For earlier products, the REN is separately shown on the label.

The plug used to connect this equipment to the premises wiring and telephone network must comply with the applicable FCC Part 68 rules and requirements adopted by the ACTA. If your home has specially wired alarm equipment connected to the telephone line, ensure the installation of this K-1900-8 does not disable your alarm equipment. If you have questions about what will disable alarm equipment, consult your telephone company or a qualified installer.

If the K-1900-8 causes harm to the telephone network, the telephone company will notify you in advance that temporary discontinuance of service may be required. But if advance notice isn't practical, the telephone company will notify the customer as soon as possible. Also, you will be advised of your right to file a complaint with the FCC if you believe it is necessary.

The telephone company may make changes in its facilities, equipment, operations, or procedures that could affect the operation of the equipment. If this happens, the telephone company will provide advance notice in order for you to make the necessary modifications to maintain uninterrupted service.

If trouble is experienced with the K-1900-8, for repair or warranty information, please contact:

**Viking Electronics, Inc., 1531 Industrial Street, Hudson, WI 54016 715-386-8666**

If the equipment is causing harm to the telephone network, the telephone company may request that you disconnect the equipment until the problem is resolved.

Connection to Party Line Service is subject to State Tariffs. Contact the state public utility commission, public service commission or corporation commission for information.

**WHEN PROGRAMMING EMERGENCY NUMBERS AND (OR) MAKING TEST CALLS TO EMERGENCY NUMBERS:**

Remain on the line and briefly explain to the dispatcher the reason for the call. Perform such activities in the off-peak hours, such as early morning or late evenings.

It is recommended that the customer install an AC surge arrester in the AC outlet to which this device is connected. This is to avoid damaging the equipment caused by local lightning strikes and other electrical surges.

### PART 15 LIMITATIONS

This equipment has been tested and found to comply with the limits for a Class A digital device, pursuant to Part 15 of the FCC Rules. These limits are designed to provide reasonable protection against harmful interference when the equipment is operated in a commercial environment. This equipment generates, uses, and can radiate radio frequency energy and, if not installed and used in accordance with the instruction manual, may cause harmful interference to radio communications. Operation of this equipment in a residential area is likely to cause harmful interference in which case the user will be required to correct the interference at his own expense.

Due to the dynamic nature of the product design, the information contained in this document is subject to change without notice. Viking Electronics, and its affiliates and/or subsidiaries assume no responsibility for errors and omissions contained in this information. Revisions of this document or new editions of it may be issued to incorporate such changes.