

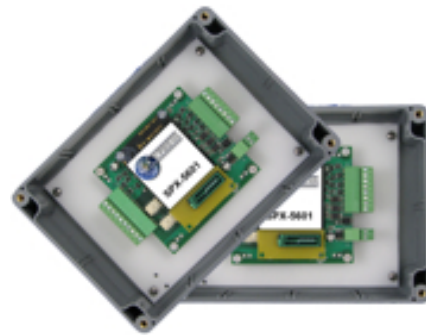

SPX-5600 Series

Operations Manual

Suprex® Reader Extender - RF Wireless Interface



SPX-5600MAN

Cypress Suprex SPX-5600 Series

SPX-5600 Series:

This manual covers the operation and setup of the Cypress Suprex RF SPX-5600 series units.

Overview:

The SPX-5600 series of RF Wireless solutions provides a wireless bridge from Card Readers with gates or door hardware to most access control manufacturers panels. The SPX or Suprex products typically include both the remote (Door/Gate) unit and the central (AC Panel) unit. In the case of the SPX-5600 series of wireless products optional repeaters / extenders are also available.

Features:

- Service mode for setup and configuration.
- “Quiet” protocol to conserve bandwidth and power
- Field configurable reader formats
- Multifunction indicator for determining operational status of the unit
- Auxiliary I/O connections available for Door/Gate/Panel status signaling.
- Multiplexing of RF bridge providing for additional door/gate on a single RF link.
- Economical expansion capabilities using Suprex Lynk technology

Electrical Specifications:

(Each Unit)

Supply Voltage 8-16VDC
Current 500mA

RF Specifications:

2.4GHz frequency
AES Encryption optional

Electrical and Mechanical Specifications

Physical	SPX-56XX - Weatherproof Enclosure 6.75" x 3.75" x 2.00" (Each unit)	
Temp	Storage(-55°C to + 150°C) Operating(-40°C to +80°C)	
Humidity	95% (non-condensing)	
Power	Input	Unreg Input 8 to 16 VDC* @ 300mA Max
	Output	+5VDC @100mA
Data I/O	Interface	Reader -Wiegand, Strobed (Clock & Data), LED - 0 - 30V

External connections and DIP Switch Settings

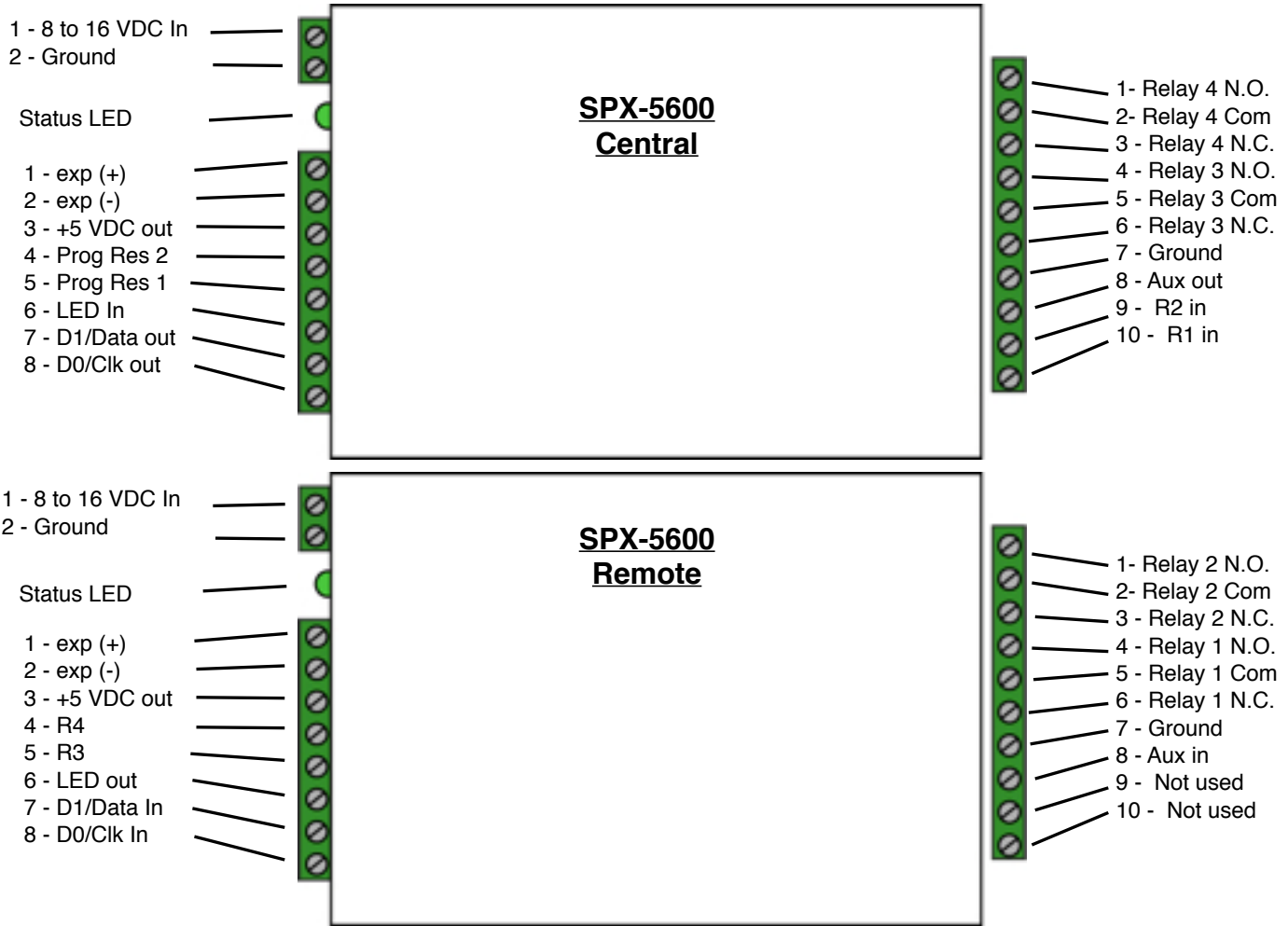

Central Unit Settings

DIP Switch #1 ON
-Service Mode
DIP Switch #1 OFF
-Run Mode

Dip switch #4 is ON
-Disable Pullup resistors

Dip switch #4 is OFF
-Enable Pullup resistors

	Switch			
	6	7	8	
Wiegand	0			
Wiegand / No Filter	1		x	x = ON
Strobed Rising Edge (MR-5)	2	x		
Strobed Rising Edge (Dorad0 644)	3	x	x	
Strobed Rising (Mag-Tek)	4	x		
Strobed Falling Edge	5	x	x	
Reserved	6	x	x	
F2F	7	x	x	

Remote Unit Settings

DIP Switch #1 ON
-Service Mode
DIP Switch #1 OFF
-Run Mode

Dip switch #4 is ON
-Enable Pullup resistors

Dip switch #4 is OFF
-Disable Pullup resistors

	Switch			
	6	7	8	
Wiegand	0			
Wiegand / No Filter	1		x	x = ON
Strobed Rising Edge (MR-5)	2	x		
Strobed Rising Edge (Dorad0 644)	3	x	x	
Strobed Rising (Mag-Tek)	4	x		
Strobed Falling Edge	5	x	x	
Reserved	6	x	x	
F2F	7	x	x	

Quick Reference For Typical Connections

SPX-5600 Series Central Quick Reference

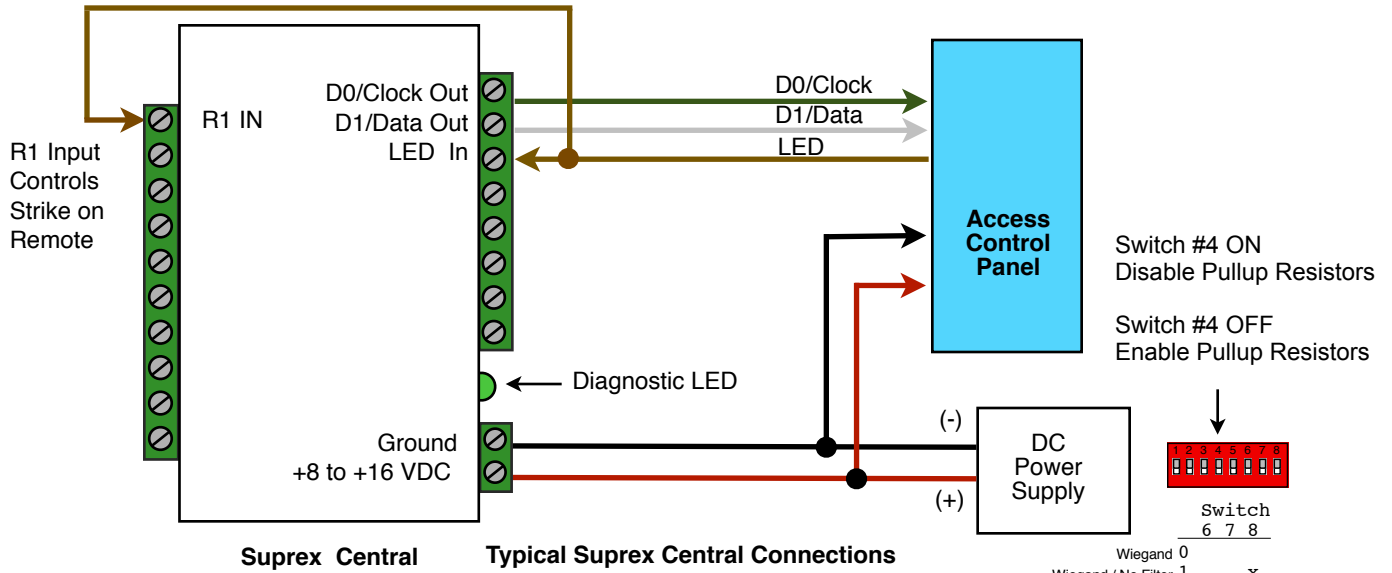

SPX-5600 Remote

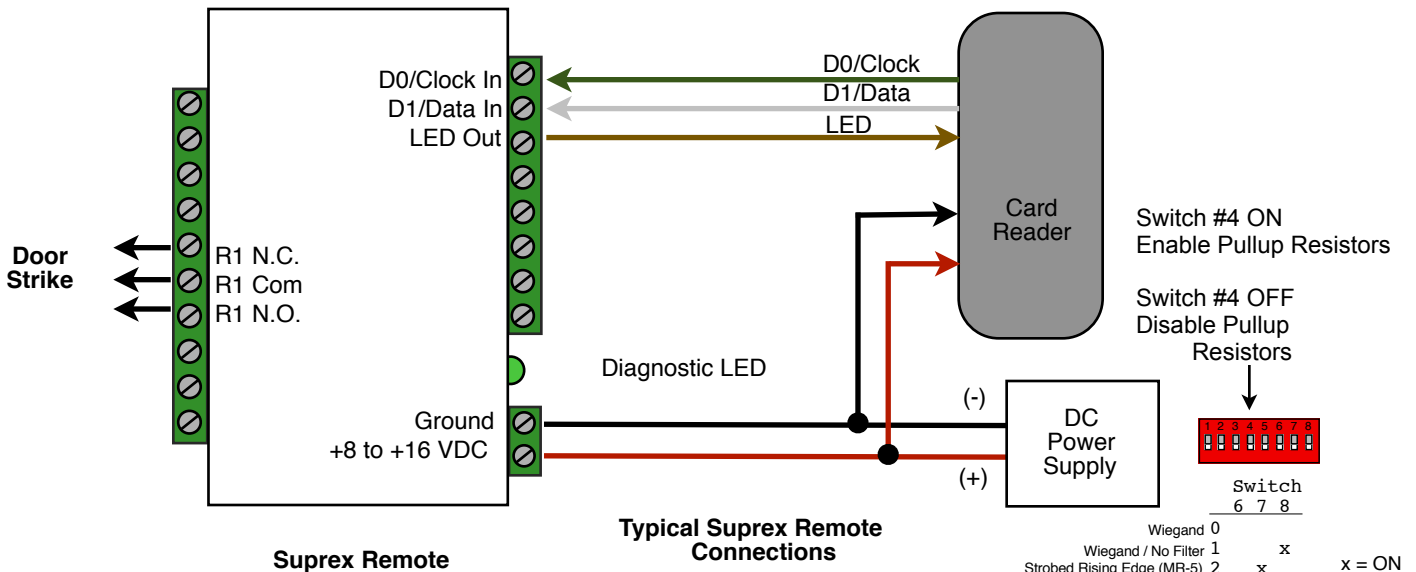

Typical RF installation with repeater

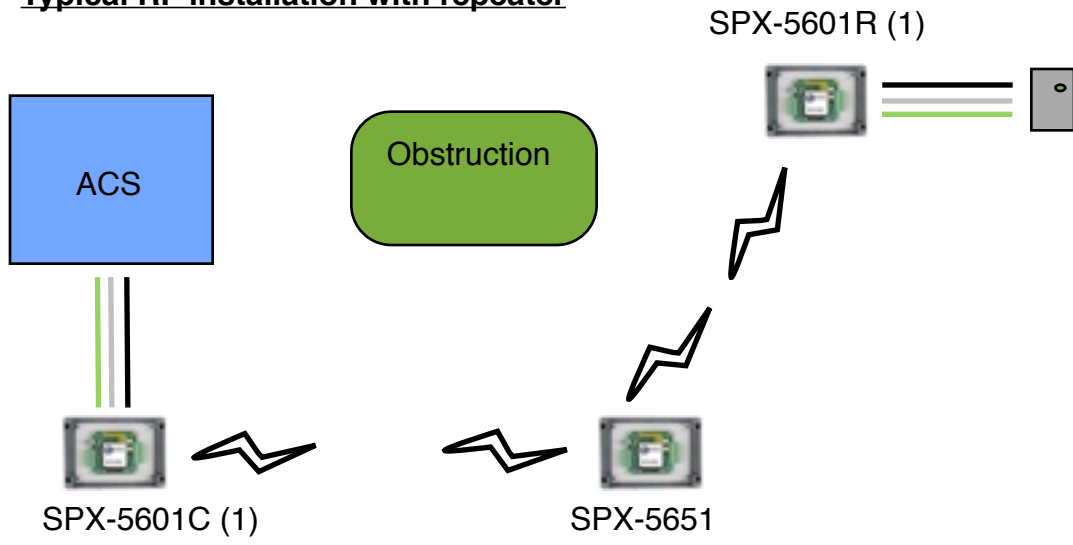

Typical RF installation - line of sight

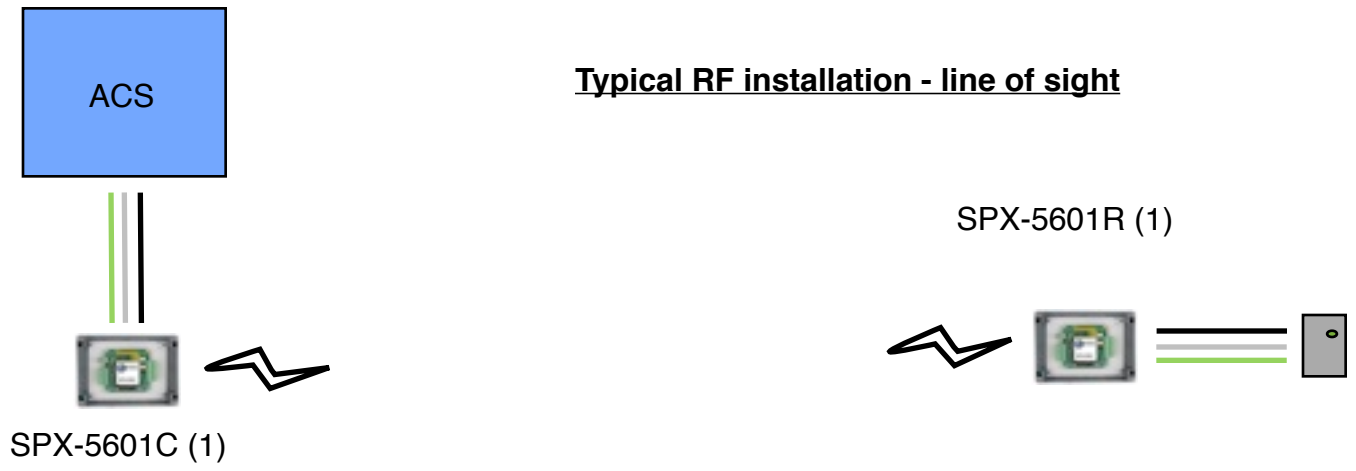

Typical RF installation - expansion modules

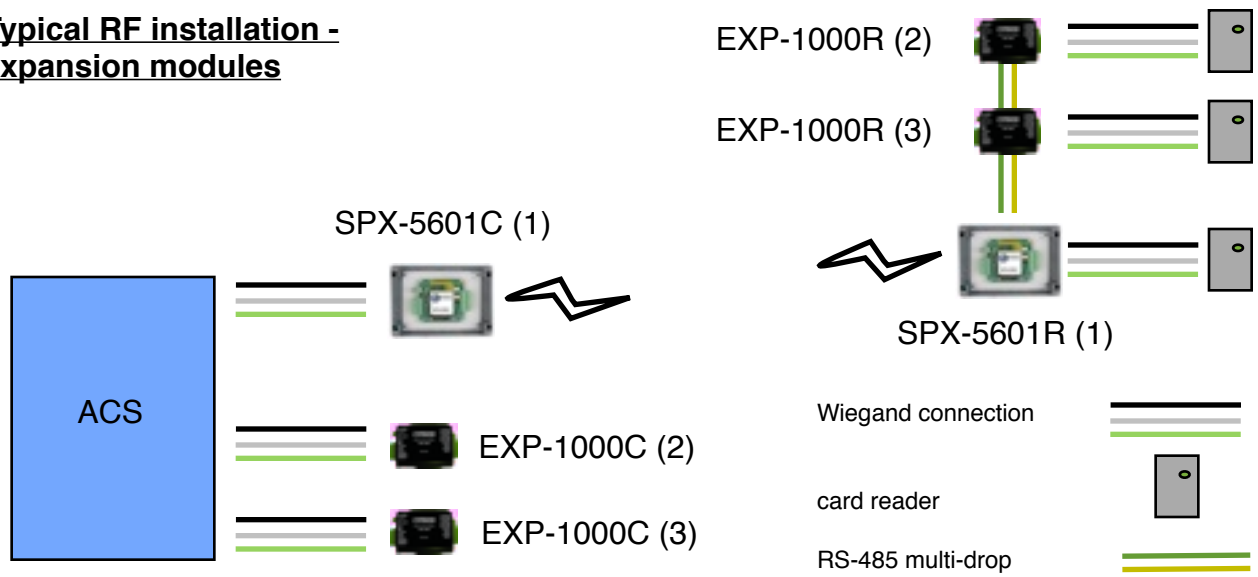

Temperature Rating vs Voltage Derating Curve

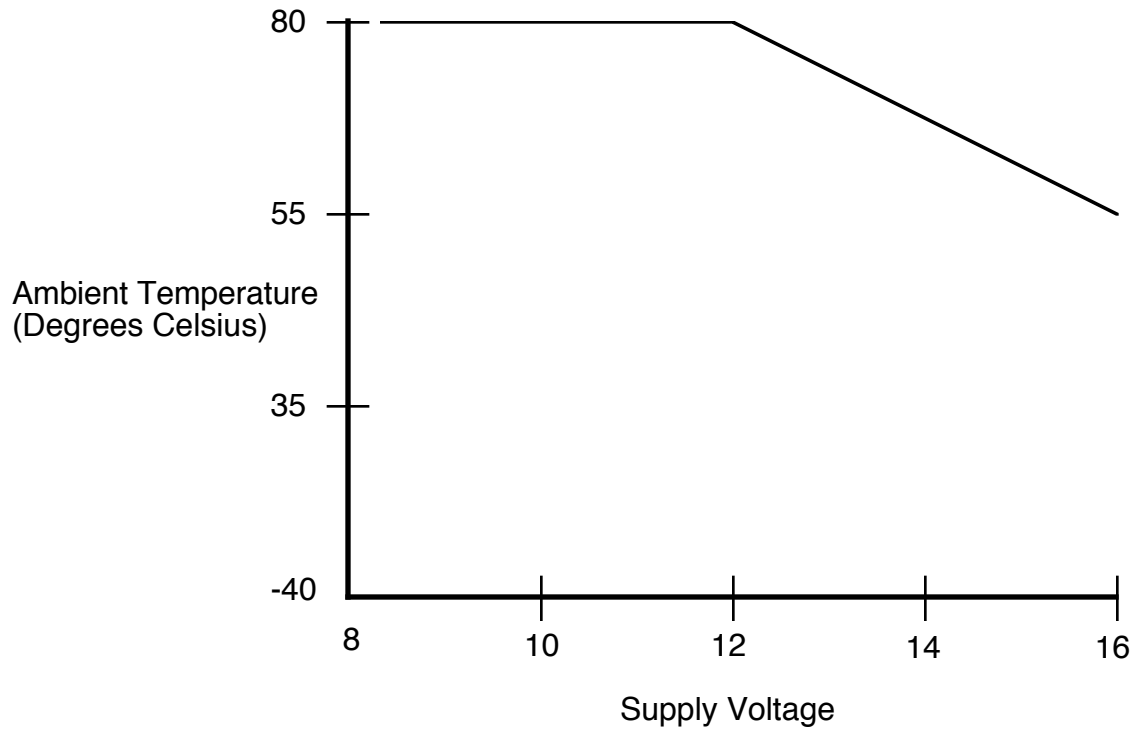

Temperature/Voltage de-rating curve

The Suprex units should be operated with a filtered 12 Volt nominal DC supply. Any voltage between 8 and 16 volts can be utilized by following the temperature /voltage derating curve. Voltage should not exceed 16 VDC under normal operating conditions.

Page left intentionally blank

Cypress Suprex RF Series - Setup and Pre-installation

Unpacking:

Remove covers from units and check interior for any shipping damage. Remove any packing material if present. Inventory any included parts (depending on model) such as antennas, coax cables etc.

Bench Testing:

Before installing the units in the field they should be assembled and tested at a convenient "Bench top" location. This will make it easier to verify / change settings and check operation when both units are visible at the same time.

It is also a chance to become familiar with the system if this is the first time using the Suprex system. It is much more difficult to setup and test the units when they are several thousand feet apart.

Both units will need to have the antenna and a suitable power supply connected. For testing purposes, the units can share the same power supply.

During initial setup it is helpful to use the Setup/Config mode. This allows a relative indication of the radio link quality between the units.

Basic Bench Test:

1. Connect any antennas if the unit was shipped without antennas installed.
2. Connect a suitable power supply to both units. Each unit should be provided with 8 - 16 volts DC and approx 300mA. Both units should be separated by a minimum of 24 inches.
3. Apply power. After about a 1 -2 second delay both units Diagnostic LED should indicate Green.
5. Touch a jumper wire from the Ground connection the the Relay 1 input on the Central unit. Relay #1 on the Remote unit should activate with an audible click and the Diagnostic LEDs should flash green on both the Central and Remote units.
6. Units are shipped from the factory set for the Wiegand data format. If a different format is required set the DIP switch to the required reader and panel format.
7. If a reader and panel is accessible, connect the reader to the Remote unit and the Central unit to the panel and verify that card reads are being accepted by the access control system. If any troubleshooting is necessary, it will be easier to do with both units in close proximity to each other.
8. Once these steps are completed, the units are ready for installation it their permanent locations and final commissioning as a system.

Cypress Suprex RF Series - Indicators and Operating Modes

LED Diagnostic Indicator:

The LED Diagnostic indicator provides information on the operational status of the unit.

If the units are not communicating, viewing the diagnostic indicator LED's may help to determine the nature of the problem.

When the Suprex units are operating correctly and have a valid communication channel between the Remote and Central units, the Diagnostic indicators on each unit will flash green rapidly (2-3 flashed per second) in Service / Config mode and illuminate a steady green in quiet mode.

DIAGNOSTIC LED NOT ILLUMINATED:

If the LED(s) are not illuminated on the unit(s) then the unit is not getting power or there is an electrical problem. The Diagnostic LED's will be illuminated Red/Green or flashing whenever power is applied.

CENTRAL UNIT FLASHING BETWEEN RED/GREEN:

With power applied and no communication path between the Remote and Central, the Central unit will flash the diagnostic indicator alternately between Red and Green.

REMOTE UNIT ILLUMINATED RED:

The Remote unit will diagnostic LED will illuminate solid (not flashing) red if it is not receiving communication from the Central.

REMOTE AND CENTRAL UNITS FLASHING BETWEEN RED/GREEN:

The Central is not Receiving communication from the Remote.

Operating modes:

By setting DIP switch 1 to the ON position, the unit is placed in Setup / Config mode. When the switch position is changed, cycle power to the unit to make the switch change take effect.

In "**Quiet**" mode (DIP switch #1 OFF) the units will remain quiet unless there is a status change, and will slowly poll each other about every 10 to 15 seconds to check the link integrity.

The **Setup / Config mode** places the units in a rapid polling sequence to allow troubleshooting and setup of the communication link.

The Suprex RF units use a quiet protocol when operating in Quiet mode. Communication between the Central and Remote unit only occurs when an event requires data transmission or contact needs to be made to maintain supervision. The RF channel remains quiet most of the time.

During setup or troubleshooting it may be necessary to observe the communication link between the Central and Remote units. The rapid polling used in the Setup / Config mode can help indicate whether the units can "See" each other. Additionally the Central unit Diagnostic LED will indicate Red when communication is lost.

In some cases an optimal mounting location can be selected by operating one of the units on a small 12 volt battery and moving the location while observing the diagnostic LED indicators.

Cypress Suprex RF Series - Door Strike and LED I/O

Note: The LED and Door Strike operation of the RF Suprex differs from previous Suprex versions.

To activate the relay on the Remote unit, connect as shown below. These connections can be used to allow the Remote relay to operate a DOOR STRIKE, GATE, or other locking hardware. Refer to following pages in this document for details of each I/O operation and connection.

There are two relays available for accessory outputs at the Remote end. Either relay can be used to provide the Door Strike or Gate activation function. This example uses Relay 1.

Wiring Example - Door Strike Follows LED

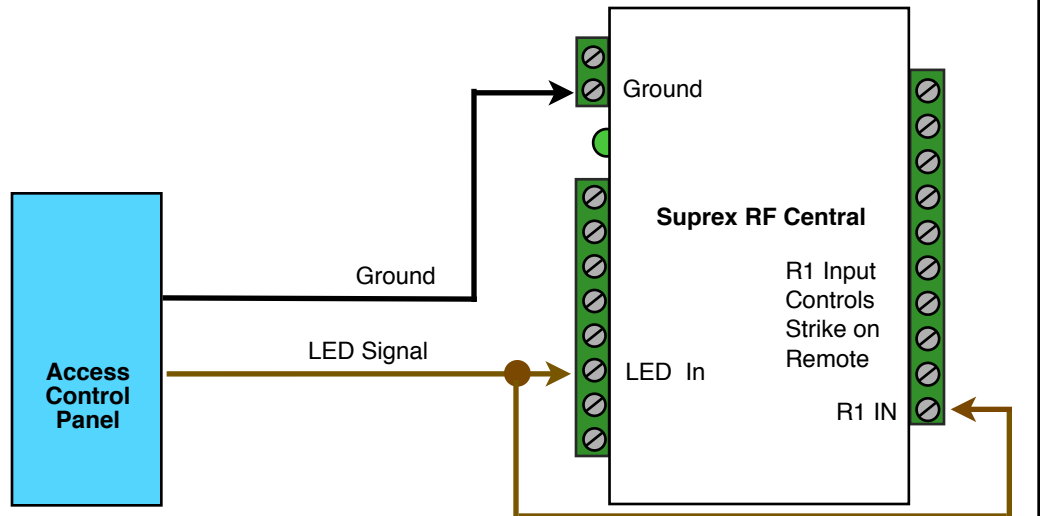

Only Relay and LED Connections are shown for clarity, refer to previous diagrams for Power and Data connections.

Wiring Example - Door Strike does not follow LED

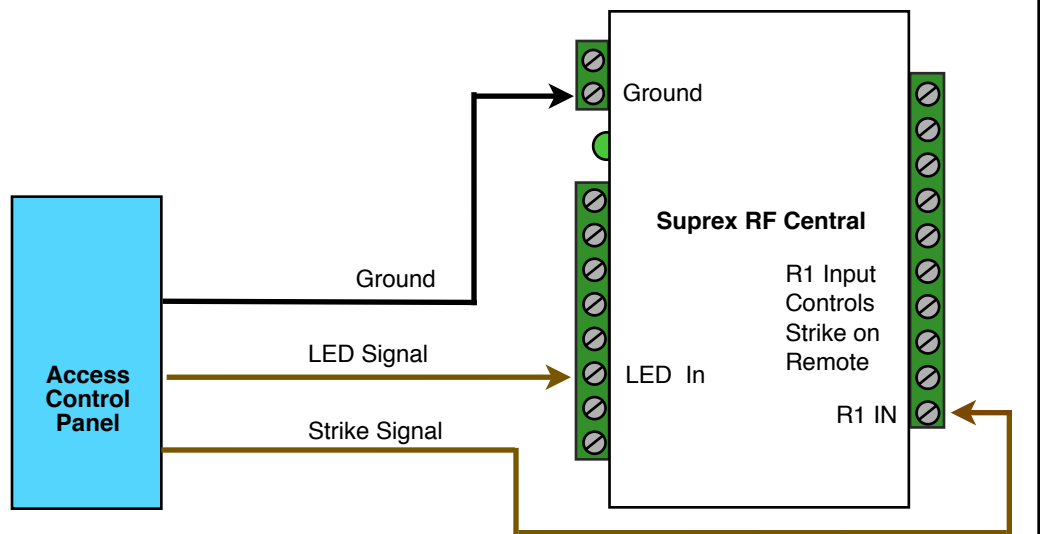

Cypress Suprex 5600 Series - Door Strike and LED I/O

The Cypress SPX-5600 provides additional data channels to support access control hardware such as door strikes, tamper alarms, request to exit status, etc. These signals are sent to and from the Remote and Central units without the need to run additional wiring.

The accessory control I/O use active low inputs. When the inputs are floating (nothing connected) the associated output will be set to a high level. When the input is set to 0Volts (Ground) the input will activate its associated output. All Accessory outputs are Open Collector type and will switch to Ground when activated.

Each input will have an associated output. See the following pages for a diagram of each I/O pair. Inputs can be tested by making a jumper connection to ground and monitoring the associated output.

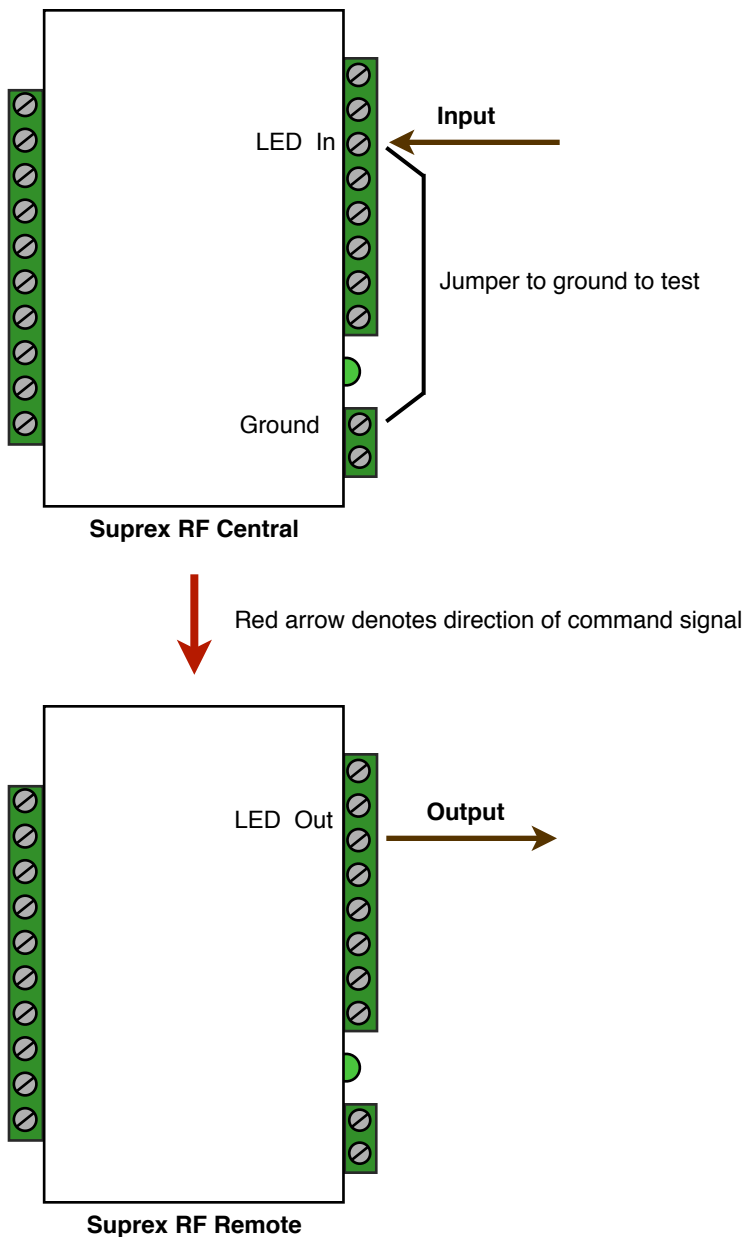

Cypress Suprex Series - Relay Controls

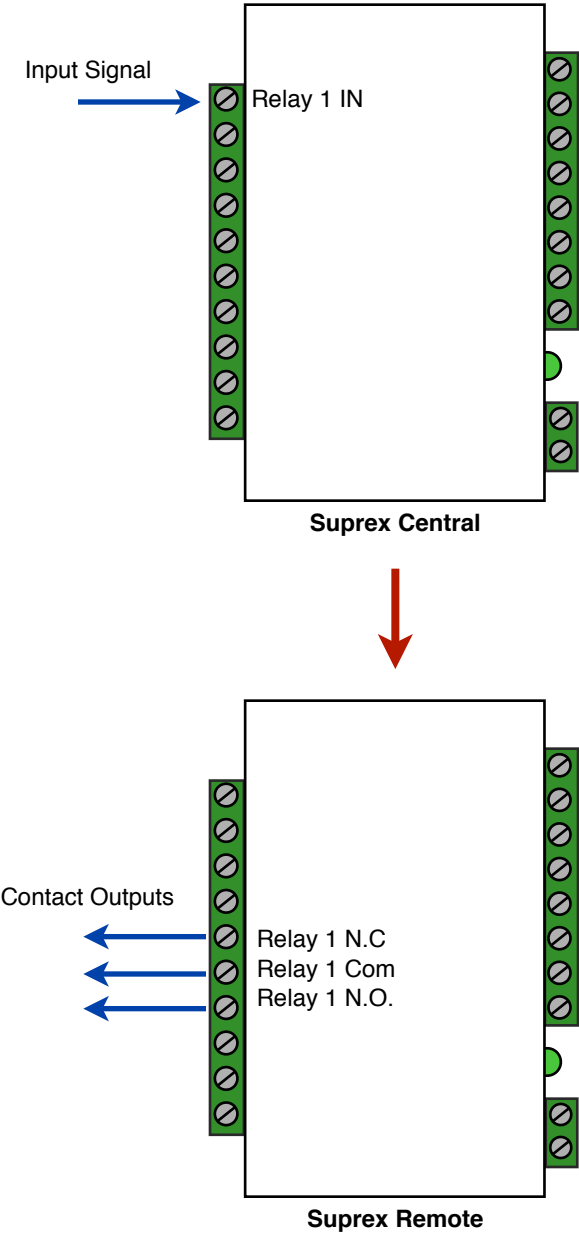

Cypress Suprex Series - Relay Controls

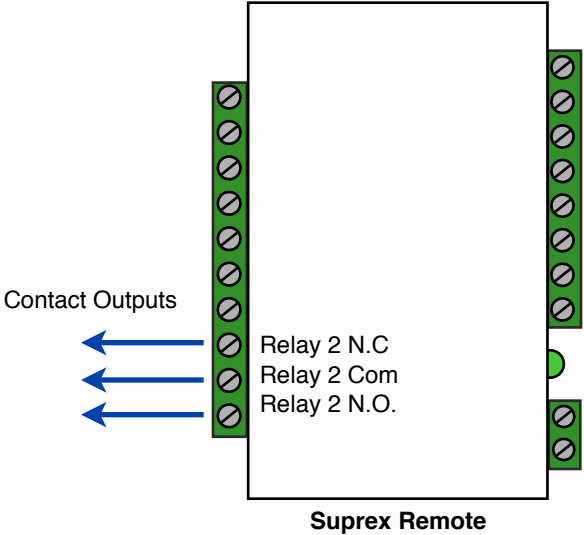
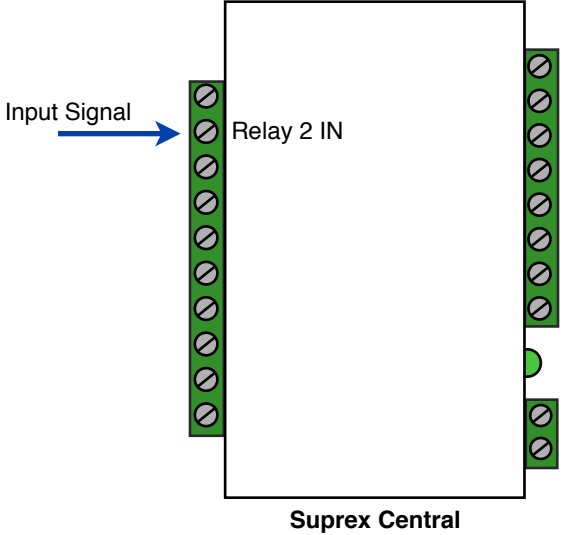

Cypress Suprex Series - Relay Controls

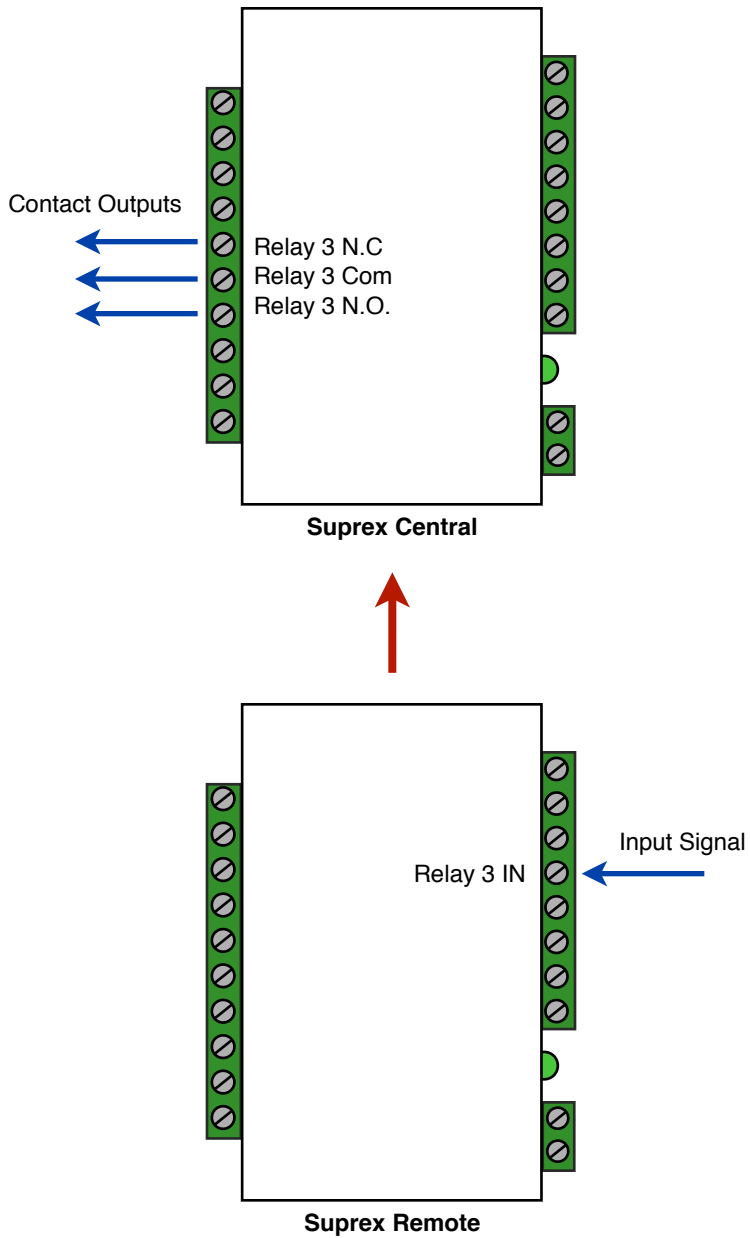

Relay 3 functions as an Alarm relay and monitors the condition of the communication link between the Central and Remote units. Relay 3 is activated when power is applied and the communication link between the Central and Remote is functioning. Relay 3 will become deactivated (Alarm condition) when either the Relay 3 input on the remote is active OR the Remote unit is unable to communicate with the Central unit.

Cypress Suprex Series - Relay Controls

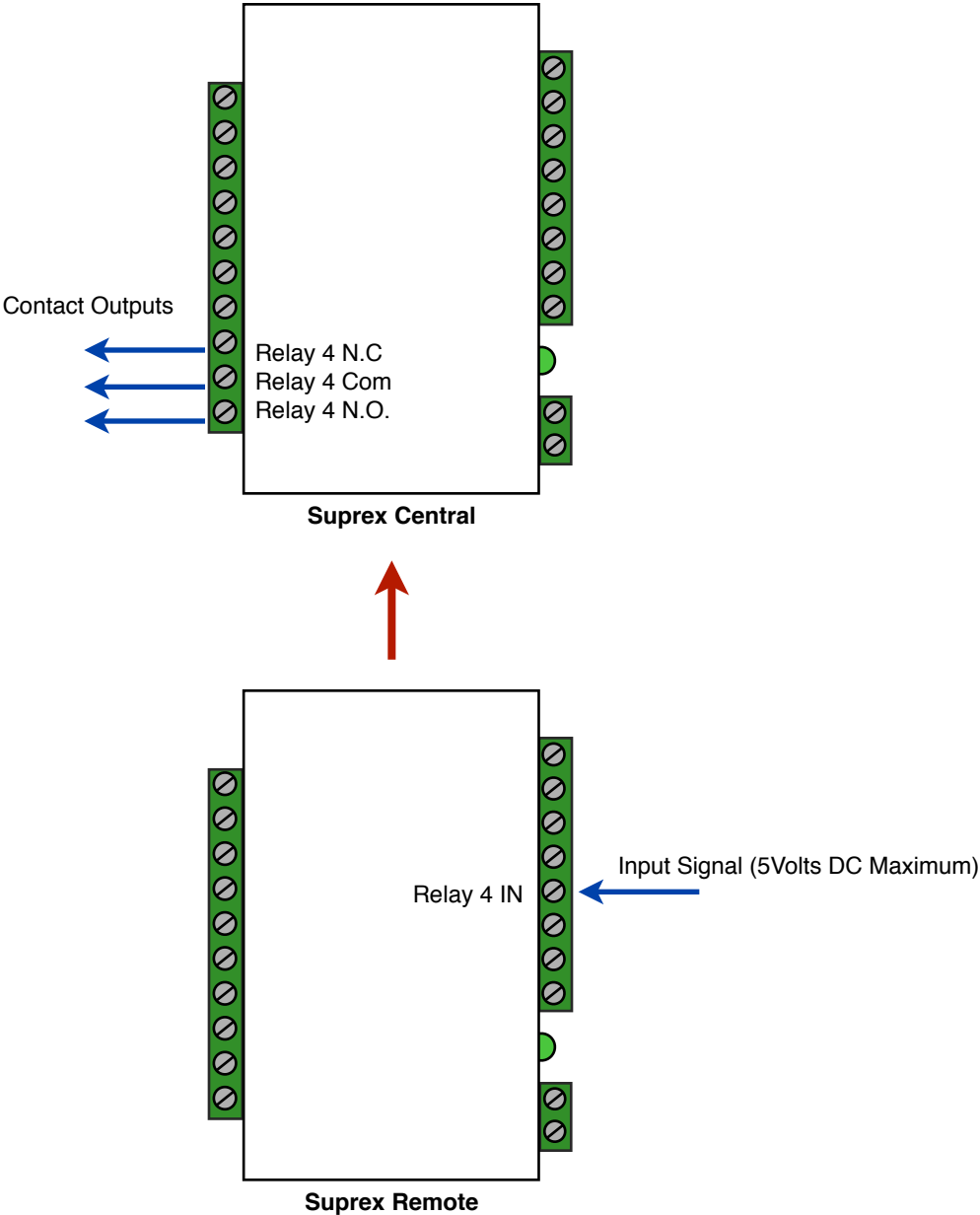

Cypress Suprex RF Series - Field Installation

Mounting the Units:

A site evaluation should have determined the optimal locations for the Central and Remote units, the type of antennas that would be needed, and the frequency band to be used. (See Cypress Application Note "Site Evaluation for Duprex RF products").

This section of the document covers units that utilize the enclosure mounted 1/2 wave whip antenna. For other types of antennas there will be specific documentation to cover their different installation issues.

We are now ready to physically mount the units and make the electrical connections to complete the installation.

The units should be mounted so that the length dimension of the antennas are in the same plane. The orientation of the antenna will determine what is referred to as the polarization of the signal. Significant reduction in range can result if the units are not oriented with the same polarity.

See below.



Both Central and Remote units are arranged so the antennas are parallel in direction. As shown in this illustration. We would say they are both vertically polarized. Since the polarity is in the same direction, the signal strength would be maximized.



In this instance one of the units is vertically polarized, and the other is horizontally polarized. The signal would be greatly reduced thereby reducing the maximum distance between units.

The installer should make sure that both units are mounted so that the polarization will be the same for both units.

In all cases the antennas MUST be mounted at a distance of 20 cm or greater from any nearby persons

Cypress Suprex RF Series - Field Installation

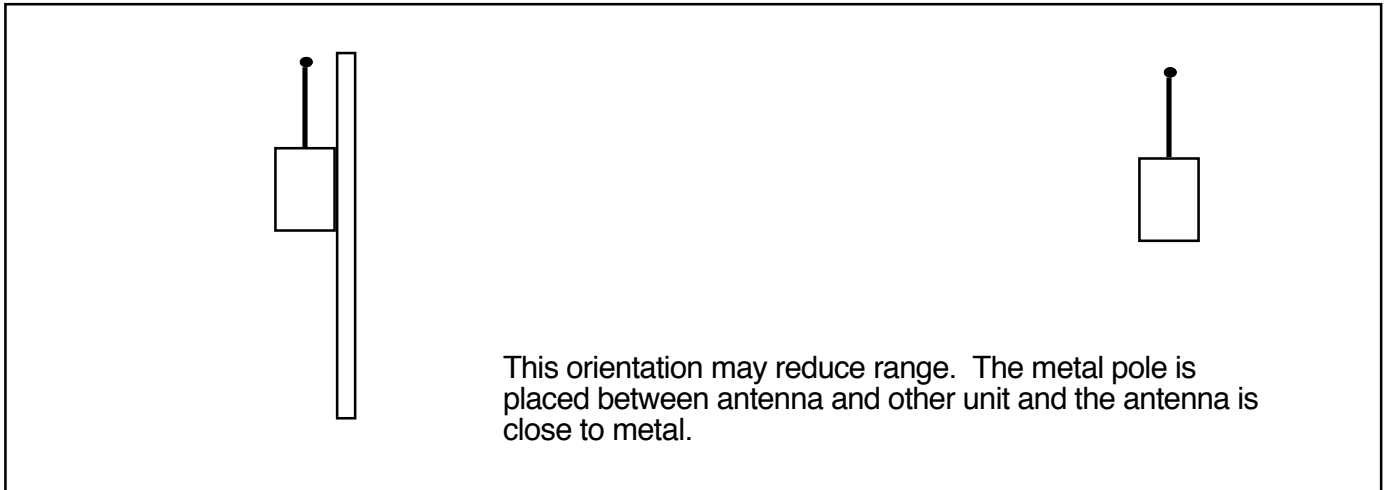

The units should be mounted in such a way that there is as clear of a path as possible between the 2 units. If mounting to a post or wall the unit should be placed where it has minimal interference with the antenna. Maximum signal and ranges are achieved when the antenna is clear of obstructions and is placed away from metal objects.

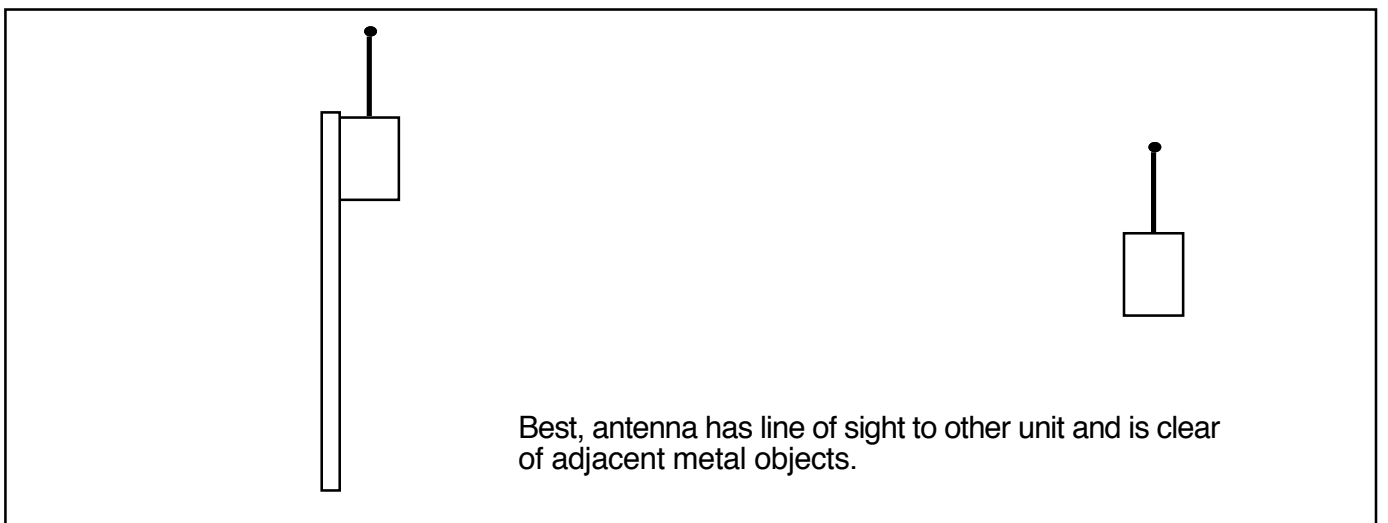
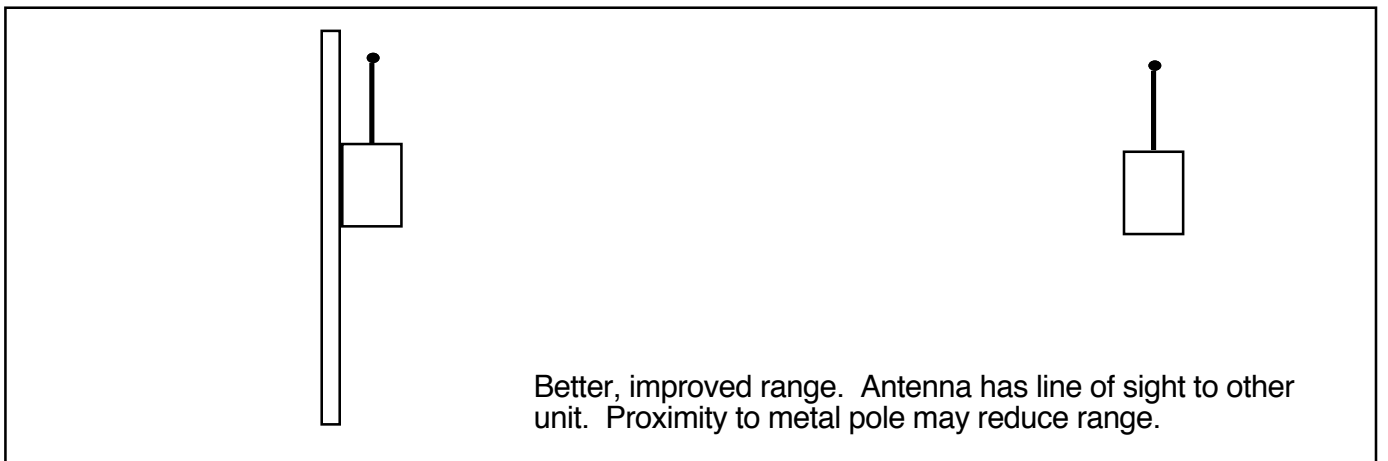

In all cases the antennas MUST be mounted at a distance of 20 cm or greater from any nearby persons

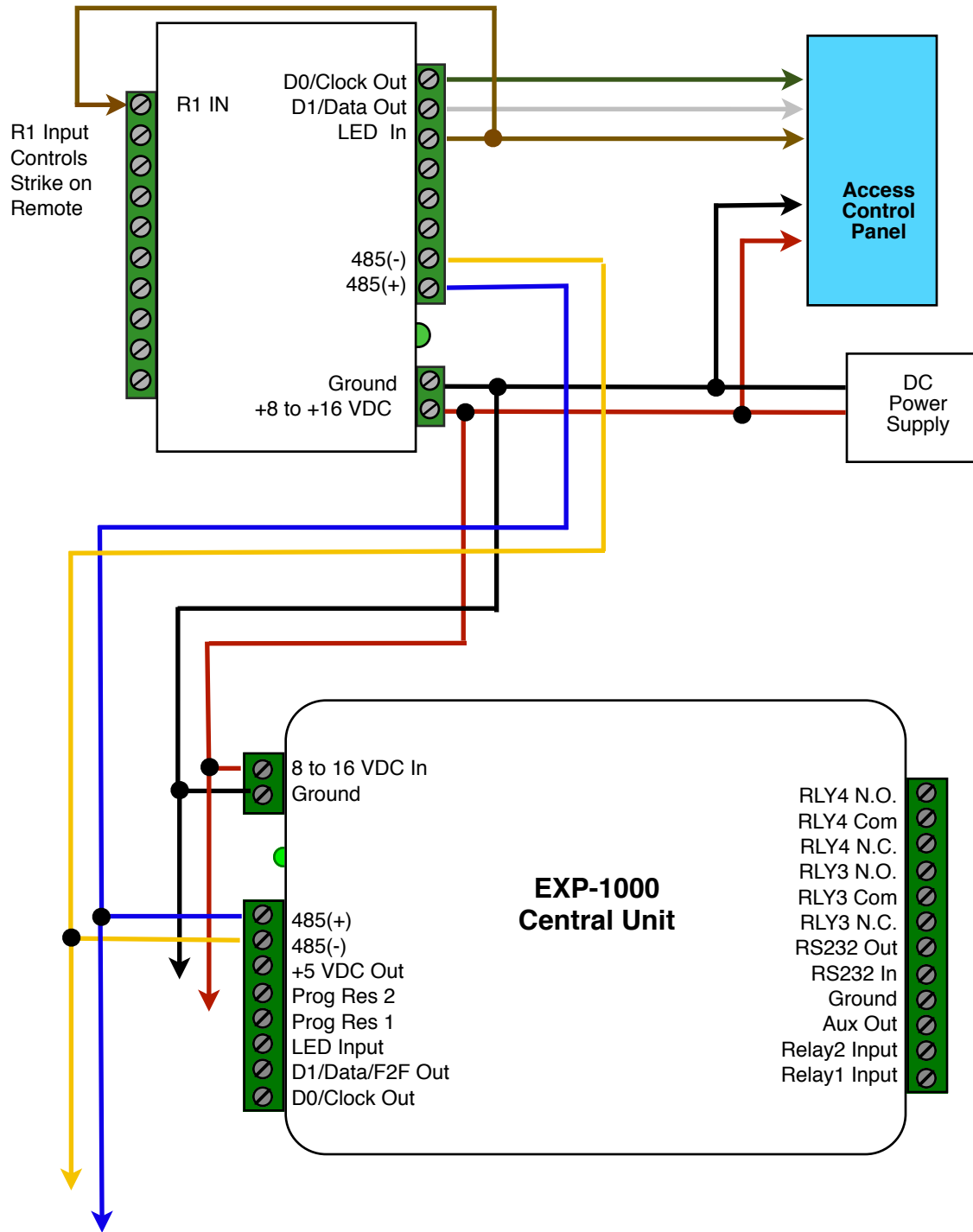

**Cypress Suprex Series - Wiegand Expansion Module
Panel "Central" interface**

Cypress Suprex Series - Wiegand Expansion Module Reader/Door "Remote" interface

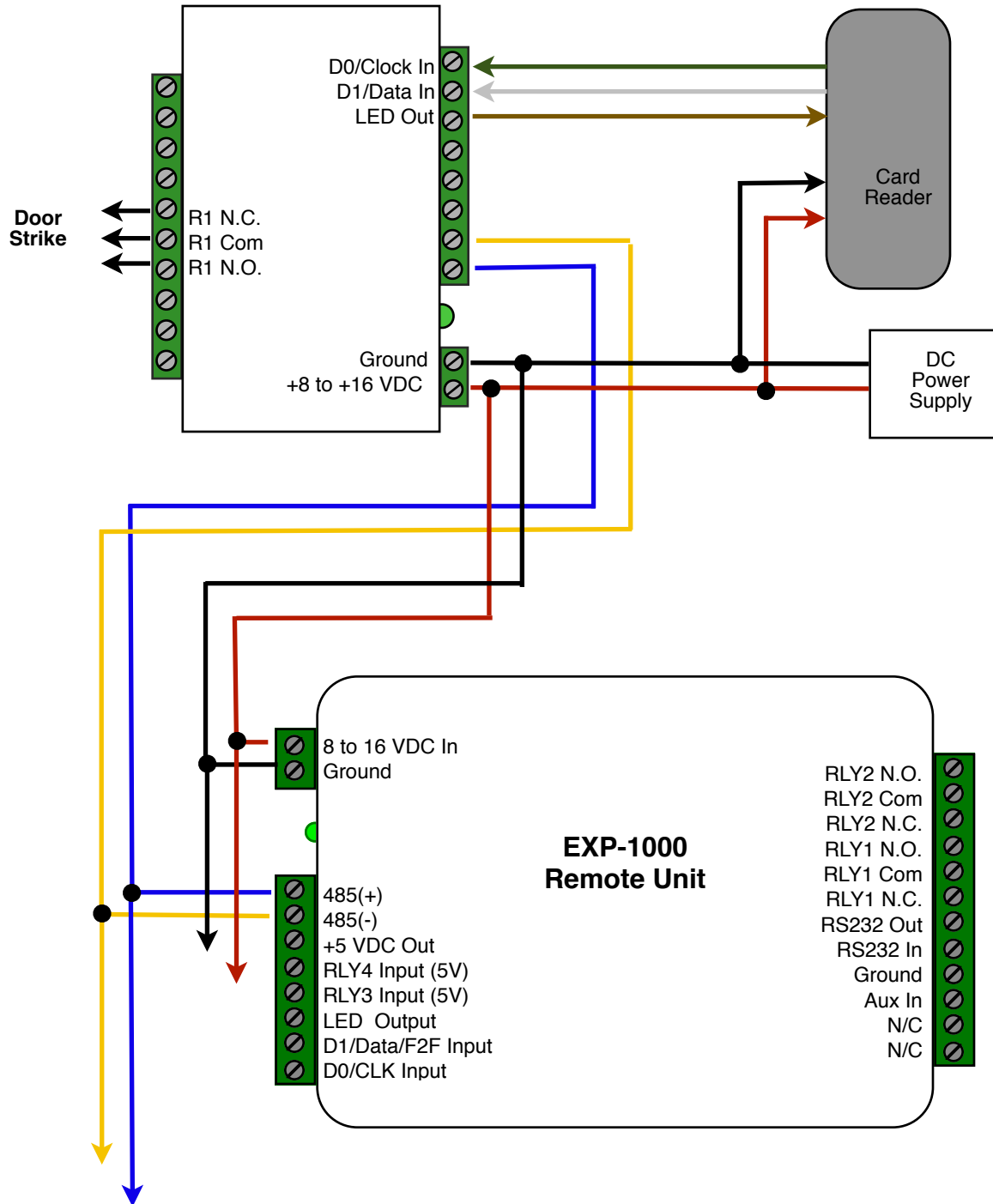

Page left intentionally blank