

Tubular Stringer Style - 2"

- 1/2" (13mm) X 1" (25mm) steel channel welded rungs
- All finishes are UL Classified as suitable as an equipment grounding conductor (File number E60548)
- Material: ASTM A513 steel tube
- Finish ___: Yellow Zinc (YZ),
Telco Gray Powder Coat (TG),
Flat Black Powder Coat (FB) or
Computer White Powder Coat (CW)

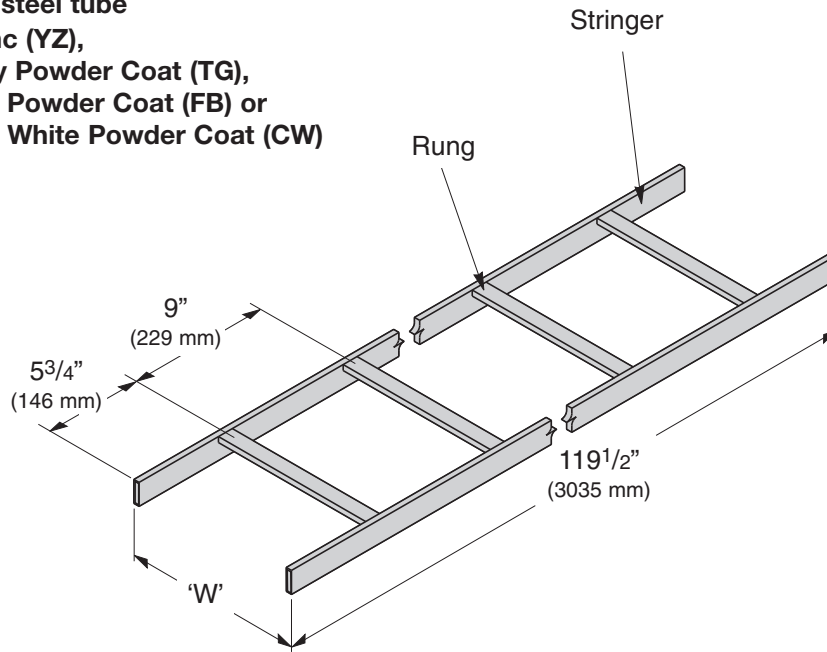

Series Number	Stringer Dimensions	Span		Load		Deflection Multiplier
		Ft.	(m)	Lbs./Ft.	(N/m)	
SB16A		4	(1.22)	254	(3707)	0.0007
		5	(1.52)	163	(2379)	0.0018
		6	(1.83)	113	(1649)	0.0037
		7	(2.13)	83	(1211)	0.0069
		8	(2.44)	63	(919)	0.0117

UL Cross Sectional Area
0.40 in ² (2.58 cm ²)
Design Factors for (1) Rail
Area = .271 in ² (1.75 cm ²)
Sx = .145 in ³ (2.37 cm ³)
Ix = .109 in ⁴ (4.53 cm ⁴)

SB16A Tubular - 2" (51mm) Stringers

Part Number	'W' Width		Weight	
	In.	(mm)	Lbs.	(kg)
SB1606A__	6"	(152)	23.6	(10.7)
SB1609A__	9"	(228)	25.8	(11.7)
SB1612A__	12"	(305)	28.0	(12.7)
SB1615A__	15"	(381)	30.1	(13.6)
SB1618A__	18"	(457)	33.7	(15.3)
SB1620A__	20"	(508)	32.3	(14.6)
SB1624A__	24"	(609)	36.6	(16.6)
SB1630A__	30"	(762)	41.0	(18.6)
SB1636A__	36"	(914)	45.3	(20.5)

Rung Profile

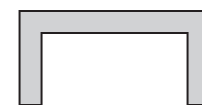

1/2" x 1"
11 gauge

Equipment Racks & Accessories

Cooper B-Line is a leading manufacturer of high quality support systems for the data communications and telecommunications industries. No matter what your application for equipment racks and accessories, Cooper B-Line has the products and accessories available to meet your needs for support networking equipment and cabling in today's high performance networks.

Our line of network equipment racks includes two-post, four-post, fixed wall mounted, swing gate wall mounted, high-density cable management and seismic Zone 4 racks. All racks are designed to meet or exceed all applicable industry standards such as EIA/ECA-310-E. Our rack products are also designed to conform to any and all requirements of applicable TIA, EIA or IEEE standards that reference racks or other equipment support products and many Cooper B-Line rack products are UL listed as well.

Cooper B-Line also offers a full line of accessories for racks including grounding and bonding equipment, rack mounted shelves, power strips, cable management devices, anchors, raised floor supports and caster bases - just to name a few.

Look to Cooper B-Line for the best-in-class options for equipment racks and accessories. We take pride in designing and manufacturing top quality, full featured products that are a cut above other manufacturer's offerings. For example, our standard two post rack features an industry leading 1,200 lb. load rating as well as valuable features like permanent RMU markings and tapped assembly holes for quick assembly.

Are we missing a component you need? Contact us. Our engineering team will be glad to discuss your needs and provide a design for your specific application. Our goal is to be your preferred supplier for all your comm/data equipment support needs.

Material:	Type	Thickness	Specifications
	Steel Bar 3/8" (9.5mm) - 7 Gauge (4.5mm) ASTM A36
	Steel Strip 10 Gauge (3.4mm) - 12 Gauge (2.6mm) ASTM A569
	Aluminum 6061-T6

Finishes:

- Brushed Aluminum (AL)
- Powder Coat Paint
 - Telco Gray (TG)
 - Computer White (CW) (also known as Alcatel Gray)
 - Flat Black (FB)
 - Silver (SL)
- Chemical Conversion Coatings Available
 - Yellow Zinc (YZ) ASTM B633
 - Black Zinc (BZ) ASTM B633



(AL)
Brushed
Aluminum

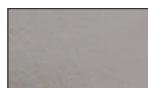

(TG)
Telco Gray



(CW)
Computer
White
(Alcatel Gray)



(FB)
Flat Black
&
(BZ)
Black Zinc



(YZ)
Yellow Zinc



(SL)
Silver

Standard Conformance:

- EIA/ECA-310-E
- UL Listed Communication Circuit Accessory (file no. E171936).
- UL Listed Communication Circuit Accessory (file no. E235184).