

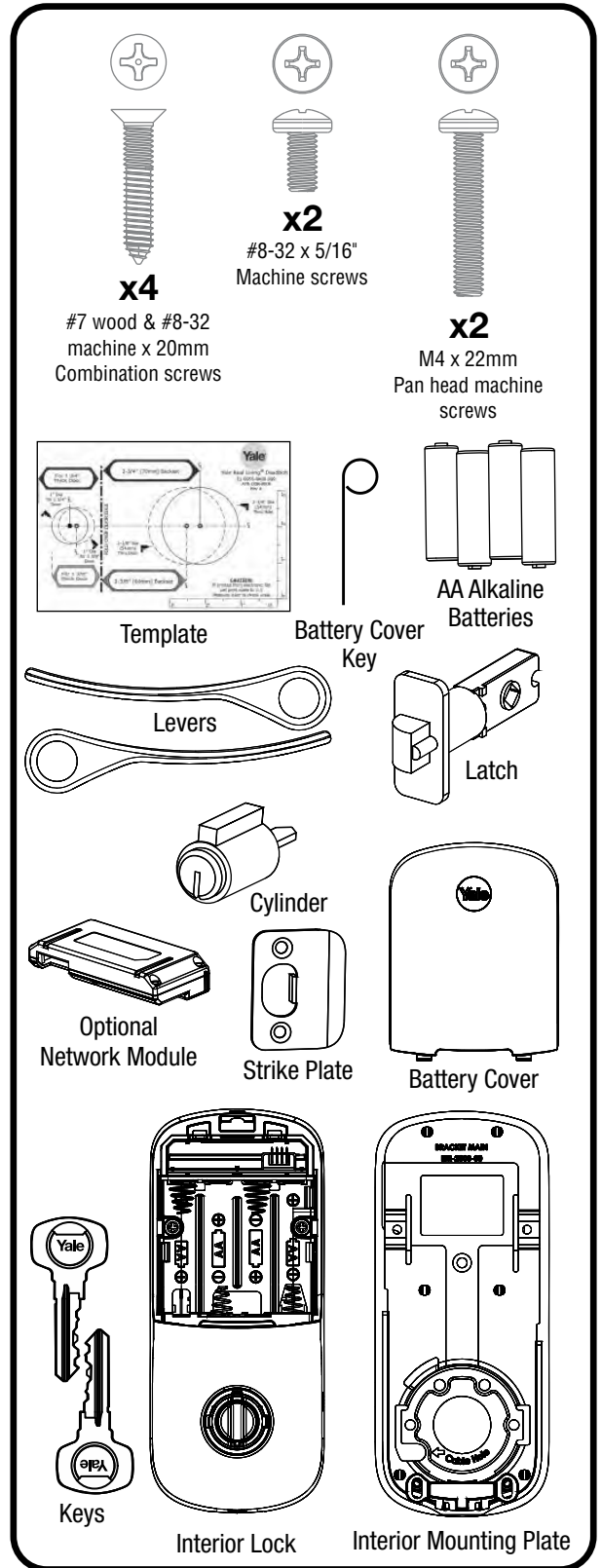

Yale *real* Living

Yale® Assure Lock® Lever Touchscreen Installation and Programming Instructions (YRL226)

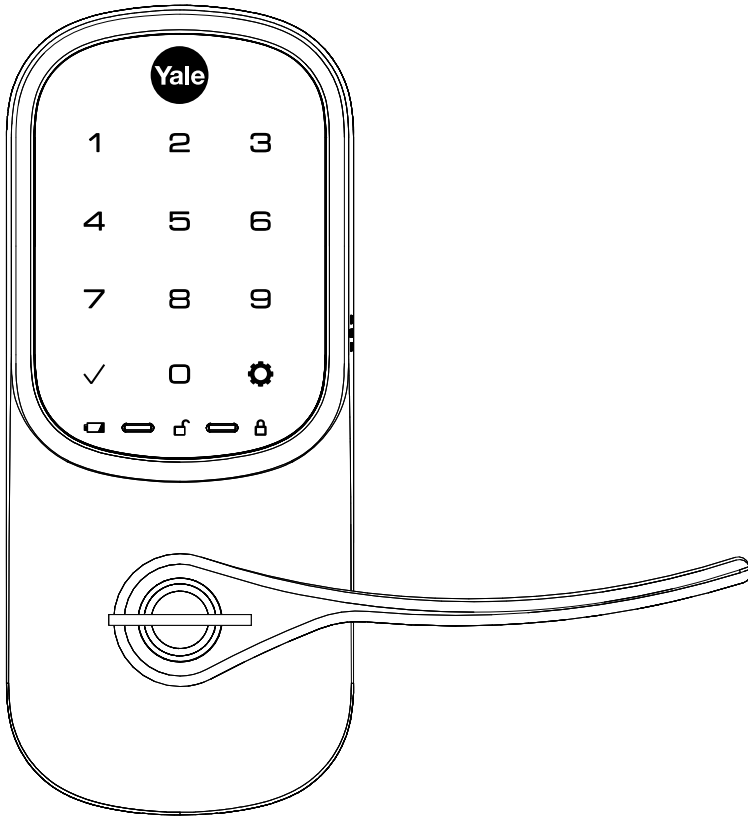

Before you begin >>>

DOWNLOAD THE BILT APP

for step-by-step installation instructions & to register your product

BILT.

Download on the App Store | GET IT ON Google Play

FAILURE TO FOLLOW THESE INSTRUCTIONS COULD RESULT IN DAMAGE TO THE PRODUCT AND VOID THE FACTORY WARRANTY

1

Installing Latch & Strike Plate Right Hand Installation Shown



x4

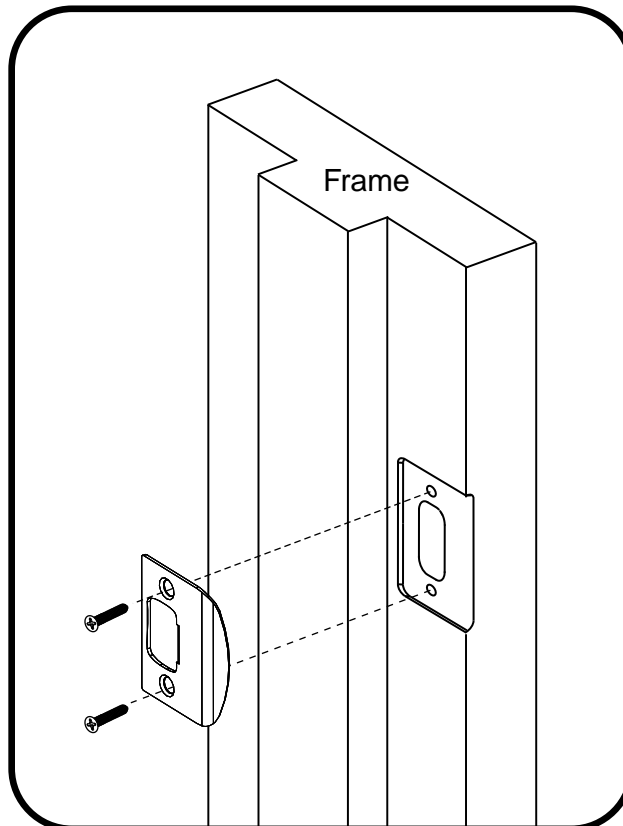
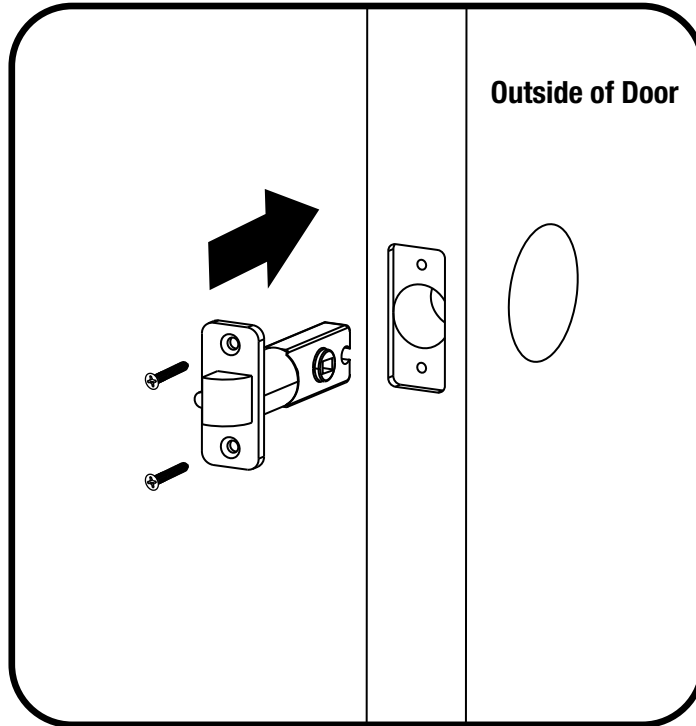

2

Installing Touchscreen Right Hand Installation Shown

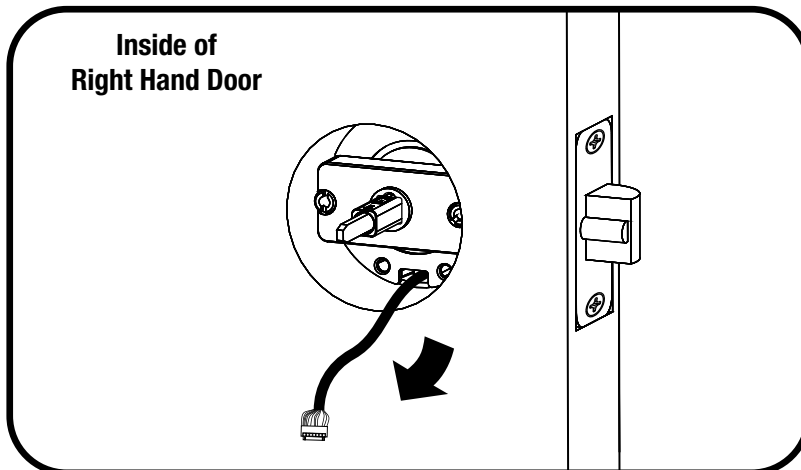
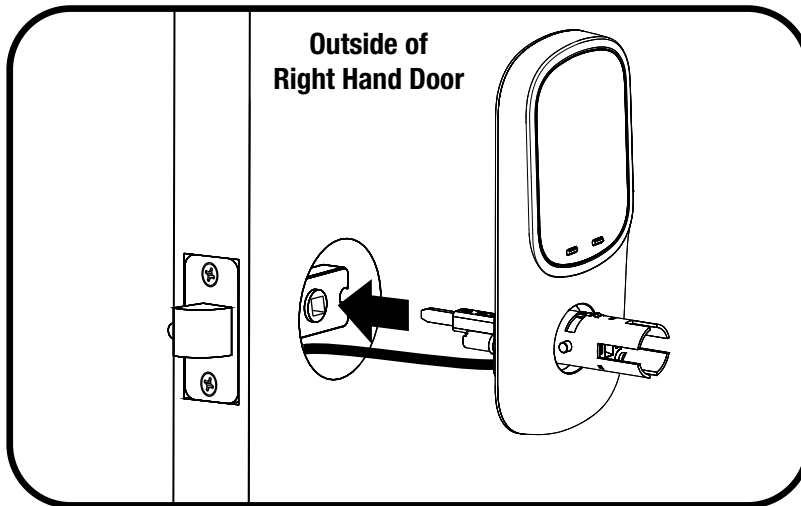
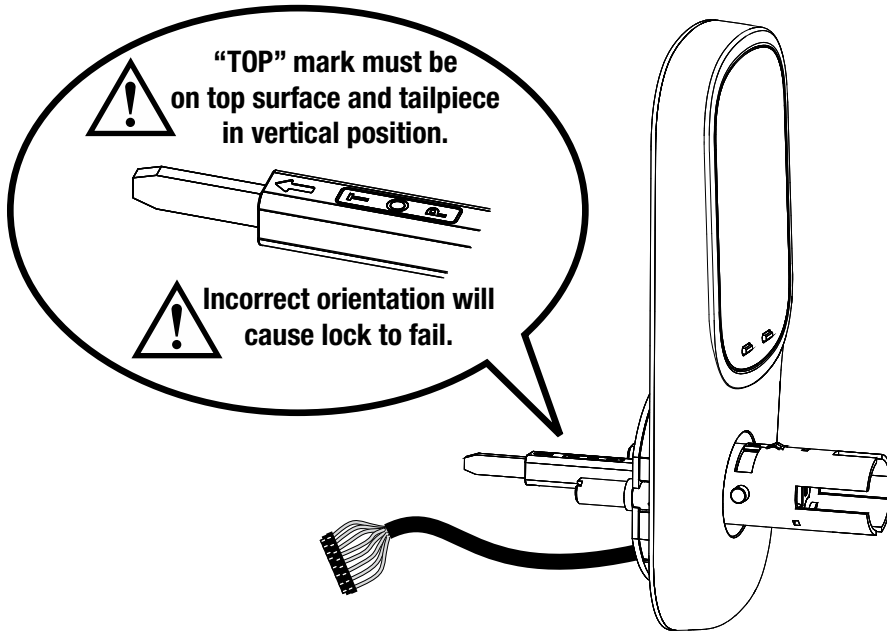

3

Installing Interior Mounting Plate Right Hand Installation Shown



x2

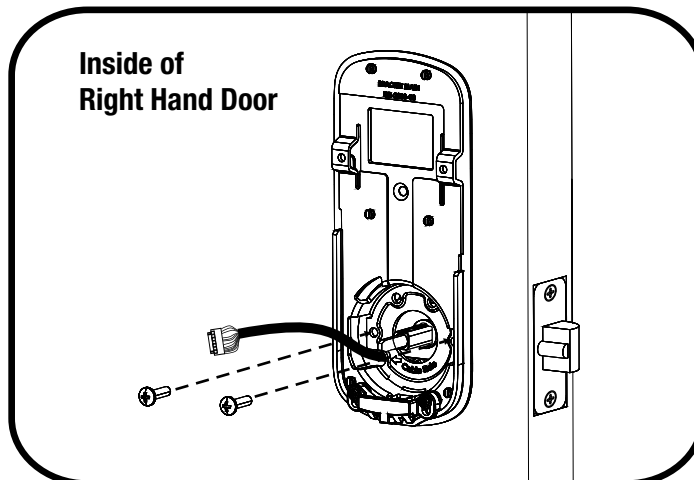
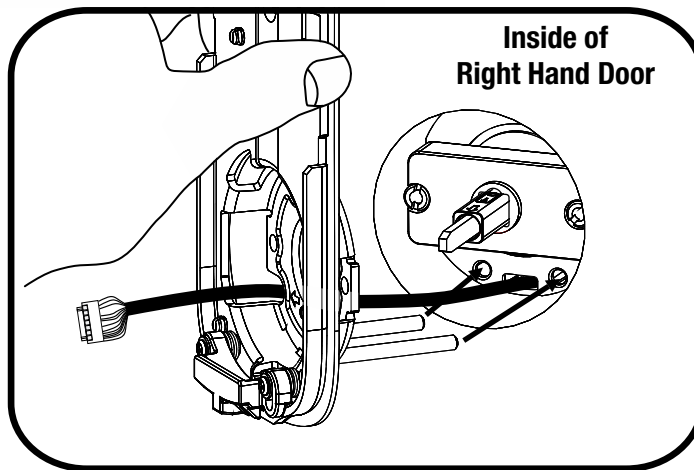
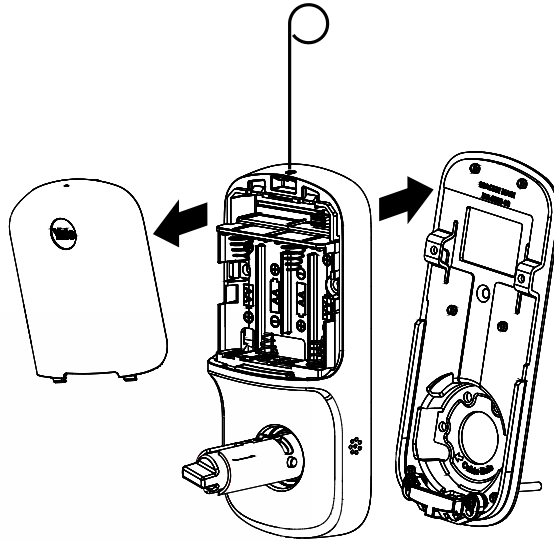

4

Attaching the Cable Assembly Right Hand Installation Shown

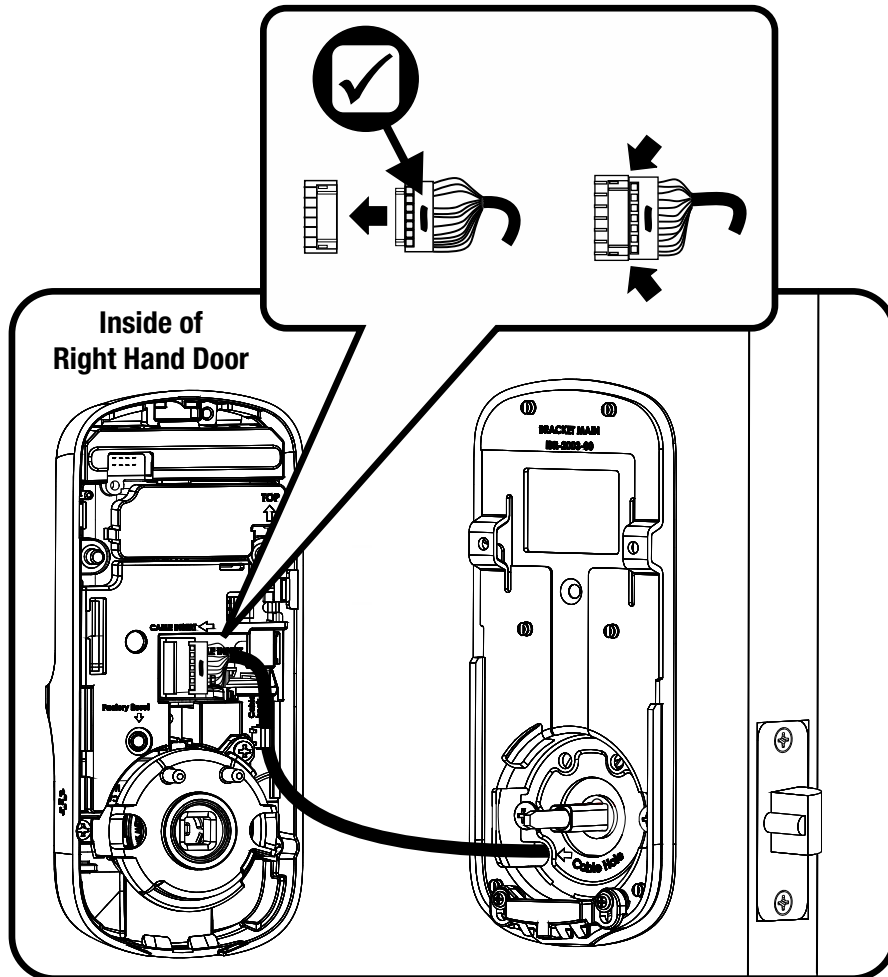
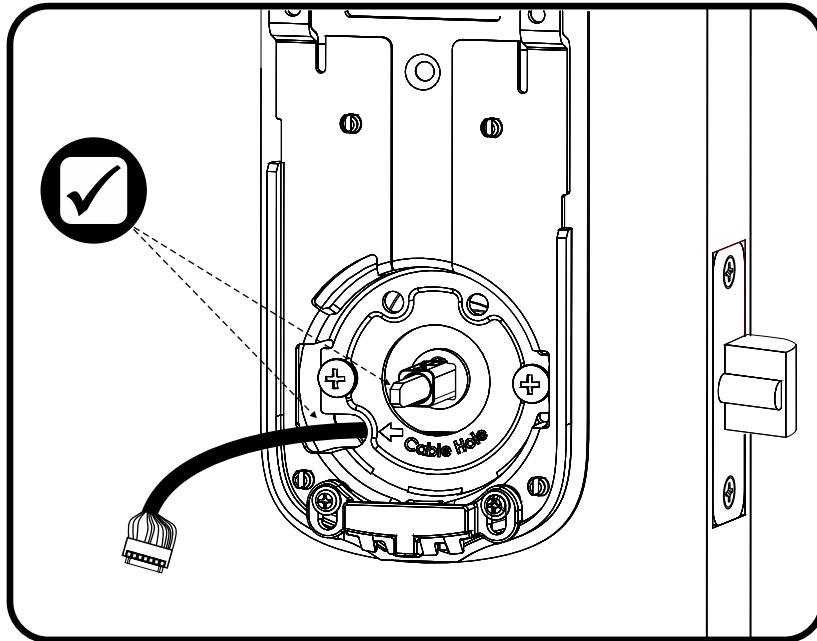

5

Installing Interior Lock Right Hand Installation Shown



X2

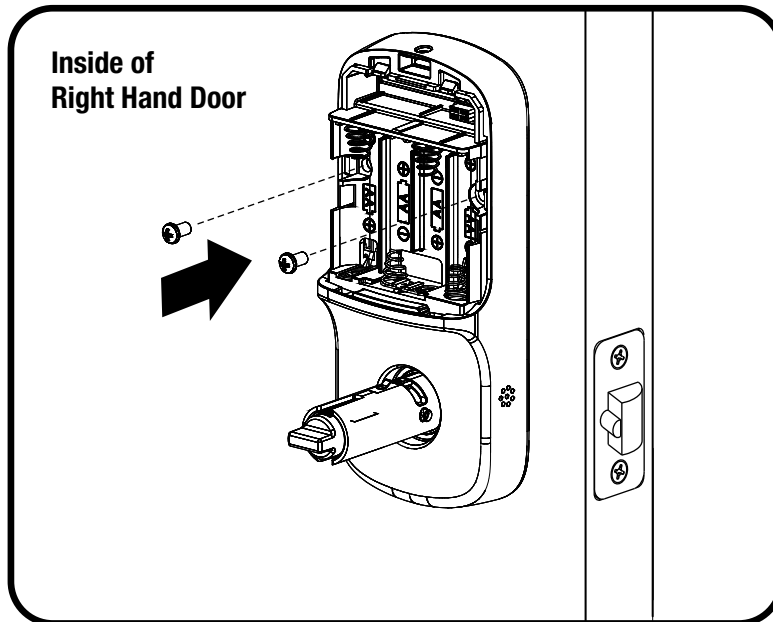
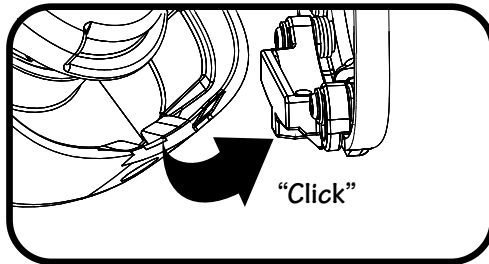
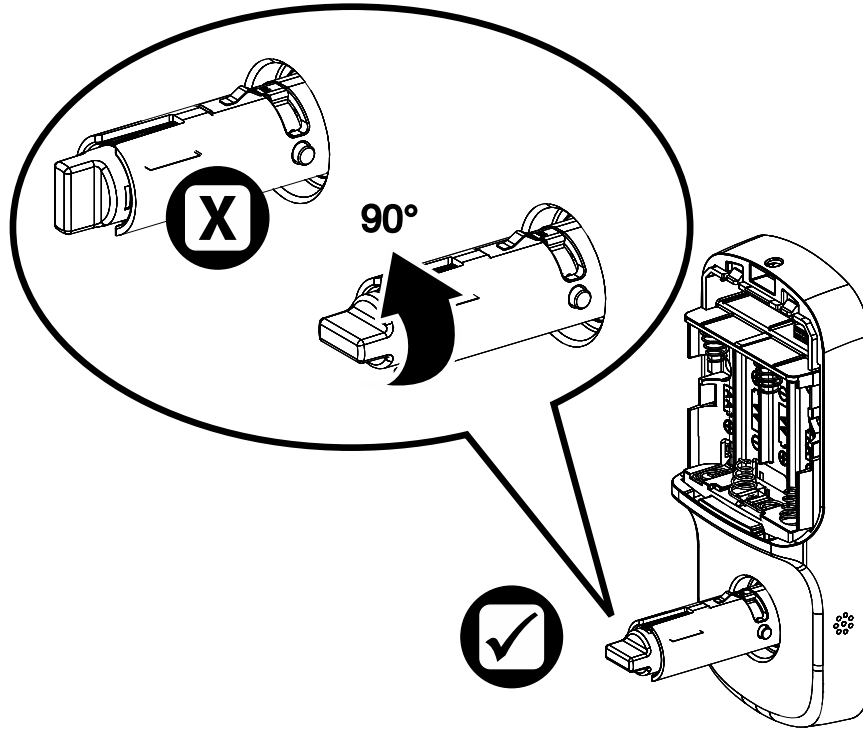

6

Installing Exterior Cylinder

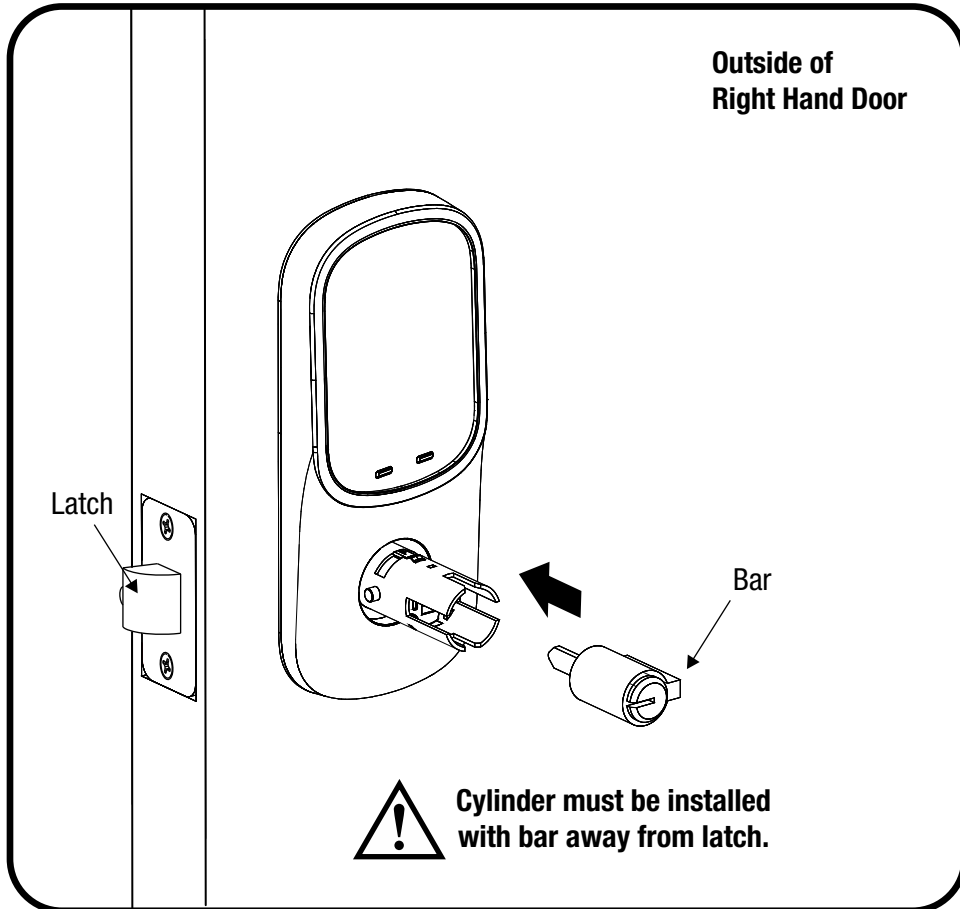
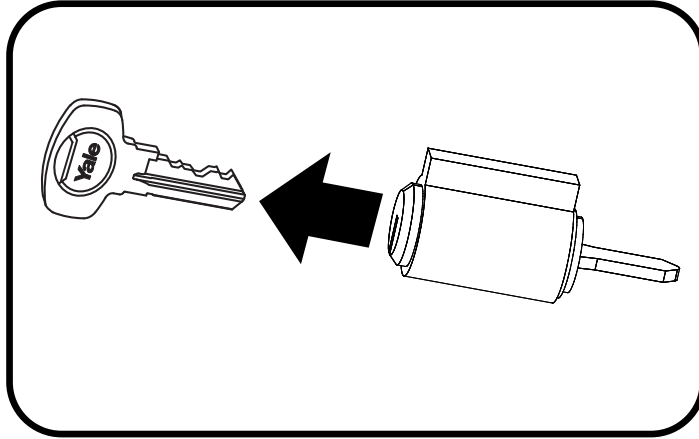

7

Installing Exterior Lever

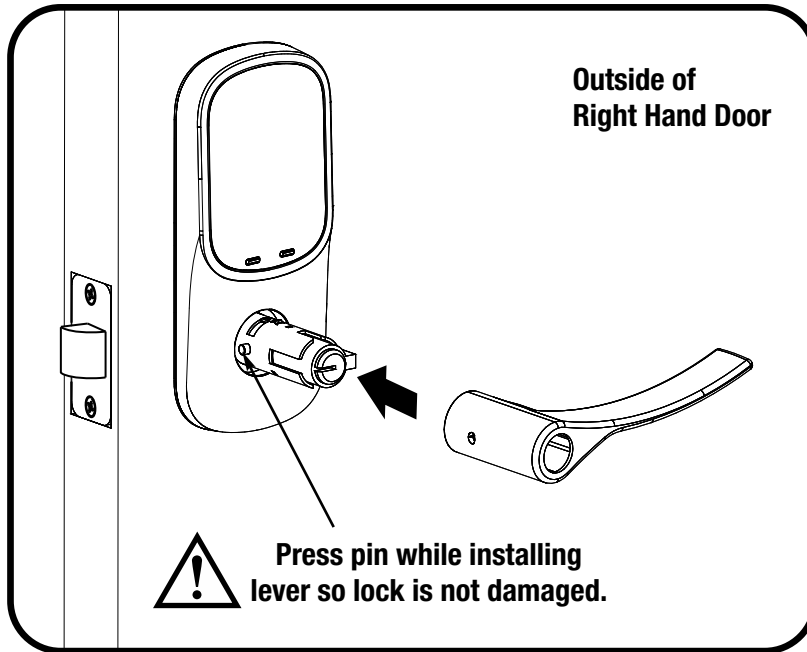

8

Installing Interior Lever

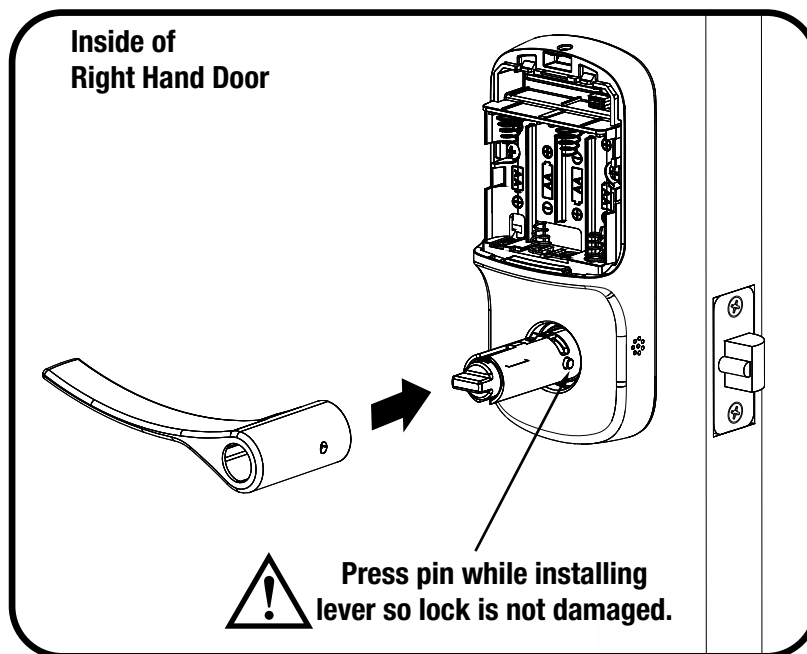

9

Installing Optional Network Module

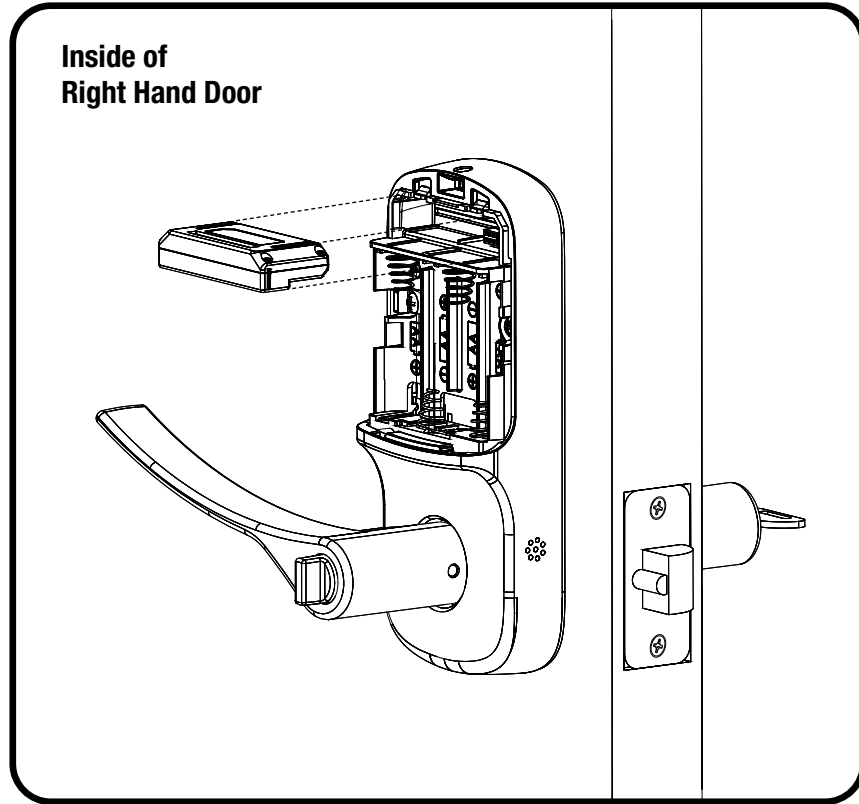

NOTE: If a network module was included with your lock, it is in a separate box with additional module installation instructions.

Resetting Lock to Factory Default

Interior Lock

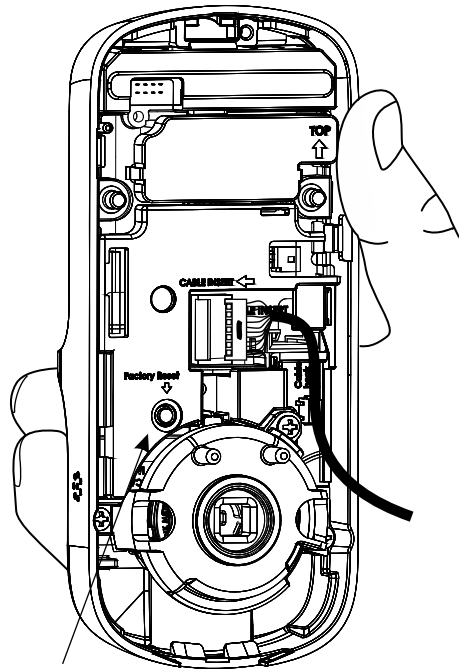

Reset Button

When resetting the lock, all user codes, including the Master PIN code*, are deleted. All programming features are reset to original default settings. See “Factory Settings”.

1. Remove the battery cover and batteries.
2. Remove the interior lock to access the reset button.
3. The reset button (see image above) is marked.
4. Re-insert 3 batteries and hold the reset button for 3 seconds.
5. While still holding the reset button, insert the 4th battery, and hold the reset button for an additional 3 seconds.
6. Release the reset button.
7. Re-install the interior lock onto the door.





*Upon reset, Master PIN Code creation is the only option available and must be performed prior to any other programming of the lock.

Hardware Troubleshooting

Cycle lock in both the locked and unlocked positions. If problems are found:

<p>Door is binding</p> <ol style="list-style-type: none">Check that door and frame are properly aligned and door is free swinging.Check hinges: They should not be loose or have excessive wear on knuckles.
<p>Bolt will not deadlock and/or lock signals failure via beeps</p> <ol style="list-style-type: none">Check for sufficient clearance of the bolt within the strike-side jamb. Correct this by increasing the depth of the pocket for the bolt.Check for misalignment of bolt and/or strike which may be preventing bolt from properly entering the strike. With the door open, extend and retract the bolt; if it is smooth, check the strike alignment.
<p>Bolt does not extend or retract smoothly and/or lock signals failure via beeps</p> <ol style="list-style-type: none">Bolt and strike are misaligned, see above.Check the backset of door relative to adjustments already made to bolt.Verify proper door preparation and re-bore holes that are too small or misaligned.Verify push button wire harness is routed properly (see Steps 2 - 4).
<p>Touchscreen numerics are scrolling</p> <p>Remove interior lock and check to ensure that the wire harness is routed properly (see Steps 2 - 4).</p>
<p>Thumbturn will not turn</p> <ol style="list-style-type: none">Remove interior lock and ensure that thumbturn moves freely.Ensure that spindle is in proper position (Step 2).
<p>Key will not turn</p> <ol style="list-style-type: none">Remove interior lock and ensure that key rotates freely.Ensure that key cylinder is properly installed in lock (Step 6).

Feature Programming Through Menu Mode Using Master PIN code*

1. Touch Yale logo  or screen with back of hand or palm to activate. 
2. Enter 4-8 digit master PIN code* followed by  key.
Lock Response: "Menu mode, enter number, press  key to continue."
3. Enter digit corresponding to the function to be performed followed by the  key.
Follow the voice commands.

*The Master PIN code must be created prior to any other programming of the lock.

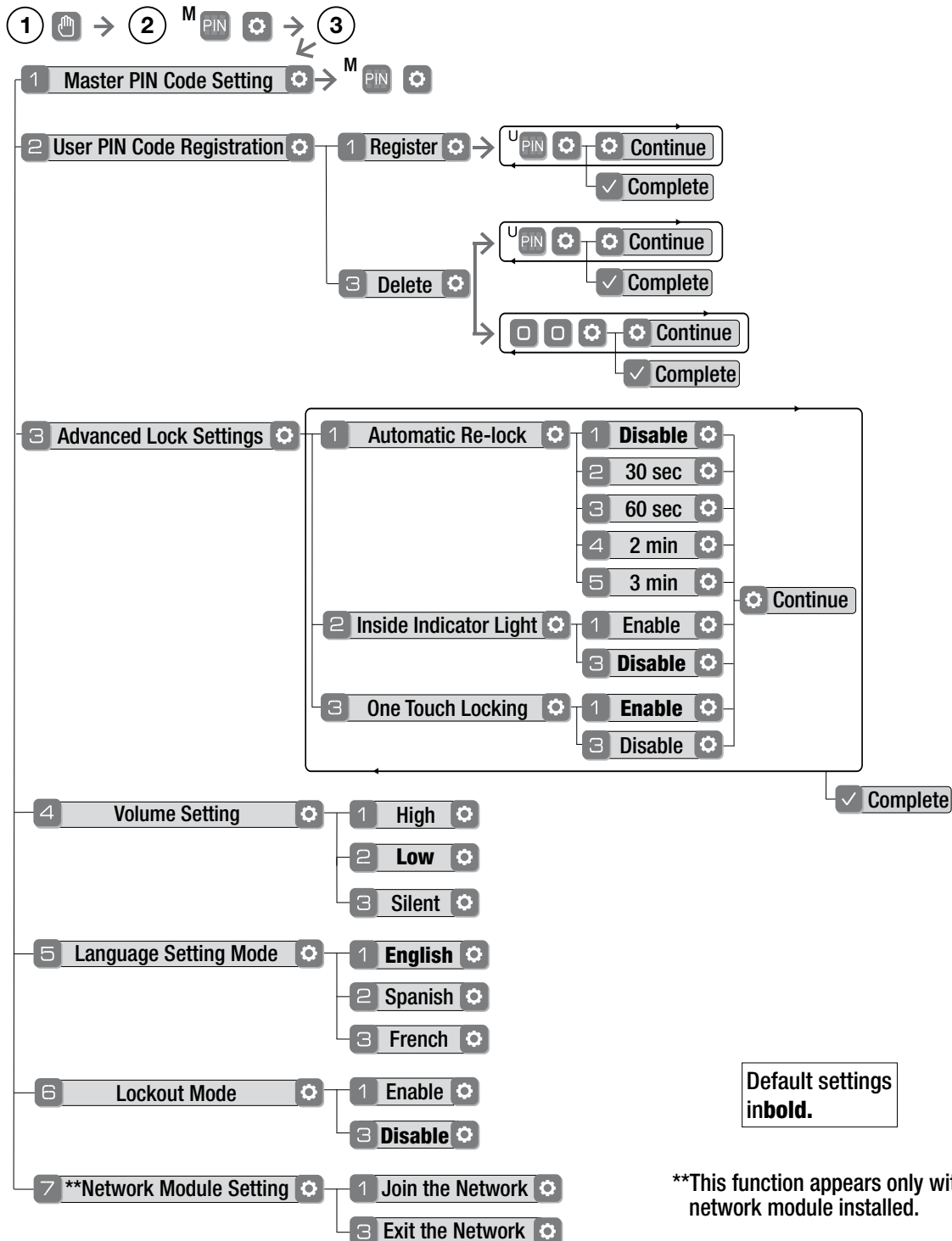

FCC:*Class B Equipment*

This equipment has been tested and found to comply with the limits for a Class B digital device, pursuant to Part 15 of the FCC Rules. These limits are designed to provide reasonable protection against harmful interference in a residential installation. This equipment generates, uses, and can radiate radio frequency energy and, if not installed and used in accordance with the instructions, may cause harmful interference to radio communications. However, there is no guarantee that interference will not occur in a particular installation. If this equipment does cause harmful interference to radio or television reception, which can be determined by turning the equipment off and on, the user is encouraged to try to correct the interference by one or more of the following measures:

Reorient or relocate the receiving antenna.

Increase the separation between the equipment and receiver.

Connect the equipment into an outlet on a circuit different from that to which the receiver is connected.

Consult the dealer or an experienced radio/television technician for help.

Warning: Changes or modifications to this device, not expressly approved by **Yale Security Inc.** could void the user's authority to operate the equipment.

Industry Canada:

This Class A digital apparatus meets all requirements of the Canadian Interference Causing Equipment Regulations.

Cet appareillage numérique de la classe A répond à toutes les exigences de l'interférence canadienne causant des règlements d'équipement.

Yale Locks & Hardware

Product Support Tel 1-855-213-5841 www.yalehome.com

Yale®, Yale Real Living® and Assure Lock® are registered trademarks of Assa Abloy Residential Group. Other products' brand names may be trademarks or registered trademarks of their respective owners and are mentioned for reference purposes only.
© Copyright 2018 All rights reserved. Reproduction in whole or in part without the express written permission of Assa Abloy Residential Group is prohibited.

Installing the Z-Wave® Plus Module

IMPORTANT: the batteries must be removed prior to removing and/or inserting the network module:



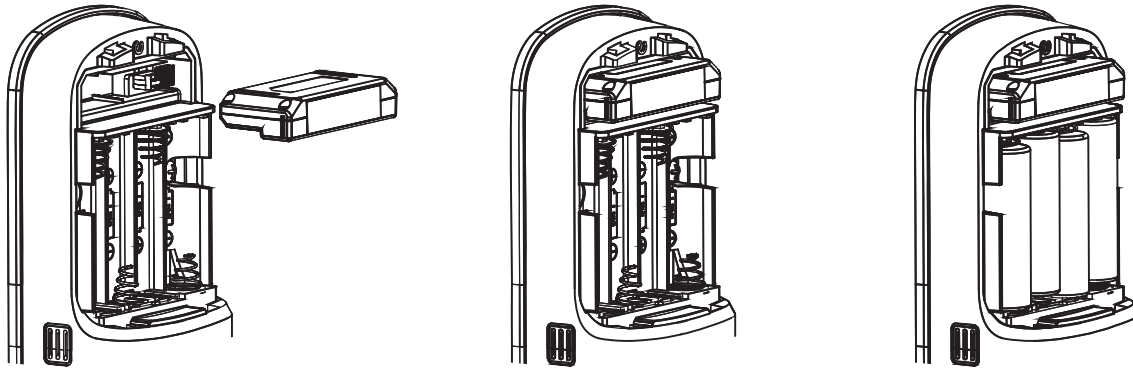
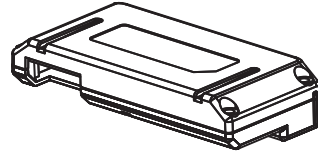

- Remove battery cover and batteries.
- Remove and/or insert Network Module.
- Reinstall batteries and battery cover.







Adding / Removing the Network Module:

This device is a security enabled Z-Wave Plus product that is able to use encrypted Z-Wave Plus messages to communicate to other security enabled Z-Wave Plus products. This device must be used in conjunction with a Security Enabled Z-Wave Controller in order to fully utilize all implemented functions. This product can be operated in any Z-Wave network with other Z-Wave certified devices from other manufacturers. All non-battery operated nodes within the network will act as repeaters regardless of vendor to increase reliability of the network.

To Add the Module (Inclusion Mode):

- Enter the 4-8 digit Master PIN code followed by the  key.
- Press the  key followed by the  key.
- Press the  key followed by the  key.

To Remove the Module (Exclusion Mode):

- Enter the 4-8 digit Master PIN code followed by the  key.
- Press the  key followed by the  key.
- Press the  key followed by the  key.

Factory Reset - If No Controller:

- See the Lock Installation Manual
- Please use this procedure only when the network primary controller is missing or otherwise inoperable.

For specific Z-Wave Plus association and parameter information for your lock, please visit YaleResidential.com/ZwavePlus



Warning: Changes or modifications to this device, not expressly approved by Yale Security Inc. could void the user's authority to operate the equipment.

FCC:

Contain FCC ID: U4A-YRHCPZWOFM

Model: YRMZW2-US

This equipment has been tested and found to comply with the limits for a Class B digital device, pursuant to Part 15 of the FCC Rules. These limits are designed to provide reasonable protection against harmful interference in a residential installation. This equipment generates, uses, and can radiate radio frequency energy and, if not installed and used in accordance with the instructions, may cause harmful interference to radio communications. However, there is no guarantee that interference will not occur in a particular installation. If this equipment does cause harmful interference to radio or television reception, which can be determined by turning the equipment off and on, the user is encouraged to try to correct the interference by one or more of the following measures:

- Reorient or relocate the receiving antenna.
- Increase the separation between the equipment and receiver.
- Connect the equipment into an outlet on a circuit different from that to which the receiver is connected.
- Consult the dealer or an experienced radio/TV technician for help.

THIS DEVICE COMPLIES WITH PART 15 OF THE FCC RULES. OPERATION IS SUBJECT TO THE FOLLOWING TWO CONDITIONS.

(1) THIS DEVICE MAY NOT CAUSE HARMFUL INTERFERENCE, AND (2) THIS DEVICE MUST ACCEPT ANY INTERFERENCE RECEIVED, INCLUDING INTERFERENCE THAT MAY CAUSE UNDESIRE OPERATION.

Industry Canada:

Contain IC: 6982A-YRHCPZWOFM

Model: YRMZW2-US

Section 7.1.2 of RSS-GEN Under Industry Canada regulations, this radio transmitter may only operate using an antenna of a type and maximum (or lesser) gain approved for the transmitter by Industry Canada. To reduce potential radio interference to other users, the antenna type

and its gain should be so chosen that the equivalent isotropically radiated power (e.i.r.p.) is not more than that necessary for successful communication.

En vertu des règlements d'Industrie Canada, cet émetteur radio ne peut fonctionner avec une antenne d'un type et un maximum (ou moins) approuvés pour gagner de l'émetteur par Industrie Canada. Pour réduire le risque d'interférence aux autres utilisateurs, le type d'antenne et son gain doivent être choisies de façon que la puissance isotrope rayonnée équivalente (PIRE) ne dépasse pas ce qui est nécessaire pour une communication réussie.

Section 7.1.3 of RSS-GEN This Device complies with Industry Canada License-exempt RSS standard(s). Operation is subject to the following two conditions: 1) this device may not cause interference, and 2) this device must accept any interference, including interference that may cause undesired operation of the device. Cet appareil est conforme avec Industrie Canada RSS standard exemptes de licence(s). Son fonctionnement est soumis aux deux conditions suivantes: 1) ce dispositif ne peut causer des interférences, et 2) cet appareil doit accepter toute interférence, y compris les interférences qui peuvent causer un mauvais fonctionnement du dispositif.

This radio transmitter 6982A-YRHCPZWOFM has been approved by Industry Canada to operate with the antenna types listed below with the maximum permissible gain indicated. Antenna types not included in this list, having a gain greater than the maximum gain indicated for that type, are strictly prohibited for use with this device.

Le présent émetteur radio 6982A-YRHCPZWOFM a été approuvé par Industrie Canada pour fonctionner avec les types d'antenne énumérés ci-dessous et ayant un gain admissible maximal. Les types d'antenne non inclus dans cette liste, et dont le gain est supérieur au gain maximal indiqué, sont strictement interdits pour l'exploitation de l'émetteur.

CAN ICES-3B/NMB-3B

Yale Locks & Hardware

Product Support Tel 800.810.WIRE (9473) • www.yalelocks.com

Yale Locks & Hardware is a division of Yale Security Inc., an ASSA ABLOY Group company.

Copyright © 2016, Yale Security Inc., an ASSA ABLOY Group company.
All rights reserved. Reproduction in whole or in part without the express written permission of Yale Security Inc. is prohibited.

YALE, with its unique global reach and range of products, is the world's favorite lock
– the preferred solution for securing your home, family and personal belongings.

ASSA ABLOY is the global leader in door opening solutions,
dedicated to satisfying end-user needs for security, safety and convenience.

Yale Locks

Z-Wave+ System Integrators Guide

Yale Assure Lever Lock

YRL 216/226

Yale Z-Wave+ Info

Manufacturer ID: Assa Abloy (0x0129)

Z-Wave Device Type: Door Lock Keypad

Z-Wave Role Type: Listening Sleeping Slave (LSS)

Product ID: 0x0F00

Product Type ID:

0x800C – YRL226-ZW2 (Touch Screen interface)

0x800B – YRL216-ZW2 (Push Button Interface)

Supported Command Classes

Command Class Z-Wave+ Info
Command Class Manufacturer Specific
Command Class Security
Command Class Device Reset Locally
Command Class Power Level
Command Class Version
Command Class Battery*
Command Class Door Lock*
Command Class Door Lock Logging*
Command Class Schedule Entry Lock*
Command Class User Code*
Command Class Time Parameters*
Command Class Time*
Command Class Association*
Command Class Association Group Info*
Command Class Notification*
Command Class Configuration*
Command Class Firmware Update Md*

* Command Class Requires Security

Association Table

Group ID	Maximum Nodes	Description	Commands
1	1	Lifeline	Command_Class_Battery, Battery_Report ; Command_Class_Notification, Notification_Report; Command_Class_Configuration, Configuration_Report; Command_Class_Device_reset_locally, Device_Reset_locally_notification

Notifications Table:

<i>Alarm Reports</i>	<i>Alarm type</i>	<i>Alarm Level (2Bytes)</i>	<i>Description</i>
Master Code changed.	0x70	0x0000	Master code was changed at keypad
		0xFB	Master code was changed over RF
User added		0x(0001-max users)	User added. Alarm level = user slot number
User deleted	0x21	0x(0001-max users)	User was deleted. Alarm level = user slot number
Tamper Alarm	0xA1	0x0001	keypad attempts exceed code entry limit
		0x0002	front escutcheon removed from main
Manual Unlock	0x16	0x0001	by key cylinder or inside thumb-turn
		0x0002	By Inside Button
RF Operate Unlock	0x19	0x0001	by RF module
Keypad Unlock	0x13	0x(0001-max users)	Where Alarm level represents user slot number
Manual Lock	0x15	0x0001	by key cylinder or inside thumb-turn
		0x0002	by one touch function (lock and leave)
		0x0003	By inside button
RF Operate Lock	0x18	0x0001	by RF module
Keypad Lock	0x12	0x (0001 – max users)	Where Alarm level represents user slot number
Deadbolt Jammed	0x09	0x0001	Deadbolt motor jammed Locking
		0x0002	Deadbolt motor jammed Unlocking
Lock Reset to Factory defaults	0x30	0x0000	lock was reset manually to factory defaults lock
		0x0001	was reset over RF with a value of 0x01;
		0x0002	was reset over RF with a value of 0x02; reserved for future use

Non Access	0x26	0x(0001-max users)	A Non Access Code was entered at the lock. Where alarm level represents user slot number
Low Battery Alarms	0xA9	0x(Current %)	Too Low to operate (Starting at 3.8V)
	0xA8	0x(Current %)	Critical Battery Level (Starting at 4.0V)
	0xA7	0x(Current %)	Low Battery (Starting at 4.2V)
Auto Lock Operate Locked	0x1B	0x0001	Auto re-lock cycle complete, locked.
Duplicate Pin-code error	0x71	0x (0001-max users)	Where Alarm level represents user slot number Alarm generated in response to add user RF cmd. This alarm is not generated when attempting to add duplicate pin at the keypad. The lock simply denies it and plays the “Denied”. Trying to duplicate the master code will result in a 0x71 0x00 alarm report.
RF Module Power Cycled	0x82	0x0001	Power to RFM was restored, sent by RF module. The lock doesn’t send any alarm to the RF module when power is cycled.
Disabled user entered at keypad	0x83	0x (0001-max users)	A disabled user pin code was entered at the keypad. Alarm Level represents user slot number.
Valid user but outside of schedule	0x84	0x (0001-max users)	A valid user can be both a normal user and a Non-Access user. If a non-access user is out of schedule this alarm will be sent instead of the non-access alarm. Alarm Level represents user slot number.
Daily Repeating Schedule Set	0x60	User ID	Daily Repeating Schedule(s) were Set (Erased/Set) for User ID specified in Alarm Level. If Alarm Level = 0xFFFF then all users were affected.
Daily Repeating Schedule Enabled/Disabled	0x61	User ID	Daily Repeating Schedule(s) were enabled/disabled for User ID specified in Alarm Level. If Alarm Level = 0xFFFF then all users were affected.
Year Day Schedule Set	0x62	User ID	Year Day Schedule(s) were Set (Erased/Set) for User ID specified in Alarm Level. If Alarm Level = 0xFFFF then all users were affected.
Year Day Schedule Enabled/Disabled	0x63	User ID	Year Day Schedule(s) were Enabled/Disabled for User ID specified in Alarm Level. If Alarm Level = 0xFFFF then all users were affected.
All Schedule Types Set	0x64	User ID	All Schedule Types were Set (erased/set) for User ID specified in Alarm Level. If Alarm Level = 0xFFFF then all users were affected.
All Schedule Types Enabled/Disabled	0x65	User ID	All Schedule types were enabled/disabled for User ID specified in Alarm Level. If Alarm Level = 0xFFFF then all users were affected.

** - The Yale lock also supports a 3rd low battery alarm, too low to operate. This alarm is sent out as a Battery Report (with value = 0xFF) through the Battery Command Class. This is the last low battery alarm level before the product stops functioning.

Configurable Parameters

<u>Configuration Parameters</u>	<u>Parameter Number</u>	<u>Size</u>	<u>Description</u>
Silent mode on/off	1	1 byte	Level control, 1 = High Volume, 2 = Low Volume, 3 = Silent. Default is 2 or Low Volume
Auto Relock on/off	2	1 byte	0x00 = OFF, 0xFF = ON default is 0x00 or OFF
Auto Relock time	3	1 byte	10 to 180 seconds default is 30 seconds
Wrong Code Entry Limit	4	1 byte	3 to 10 default is 5 times
Language	5	1 byte	1=English, 2=Spanish, 3=French default is 1= English
Shut down time (after wrong code entries)	7	1 byte	10 to 180 seconds default is 60 seconds
operating mode	8	1 byte	00 = normal mode (this is the default mode) 01 = vacation mode, keypad lockout
One Touch Locking	11	1 byte	0x00 = OFF, 0xFF = ON default is 0xFF or ON.
Lock Status LED	13	1 byte	0x00 = OFF, 0xFF = ON default is 0x00 or OFF.
Reset To Factory Defaults	15	1 byte	01 = Lock will execute Reset To Factory. No default value